

**Sonder
Special**

**Gewindefräser aus VHM
Carbide Thread Mills**

Firma / Company: _____

Tel.: +____ (____) _____ -____

Kontakt / Contact: _____

Fax.: +____ (____) _____ -____

Abteilung / Department: _____

E-Mail: _____ @_____

Datum / Date: _____

Land / Country: _____

Menge / Quantity: _____ / _____ / _____

Gewünschter Termin /
Delivery Deadline: _____

* Steigung / TPI

* $l_1 =$

Entgratstufe /
Deburring

Yes
No

Tol. =

* $D =$

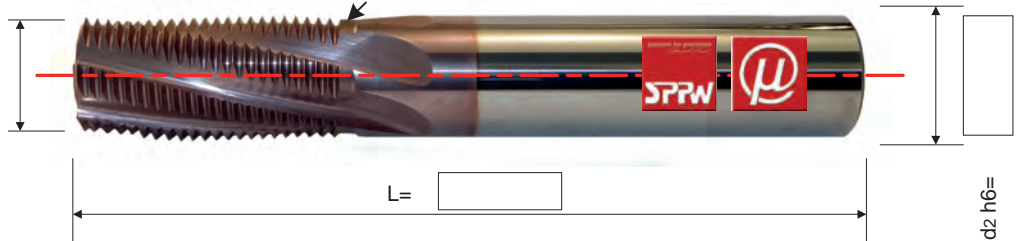

Alternative

Durchgangsloch
Through Hole

Grundloch
Ground Hole

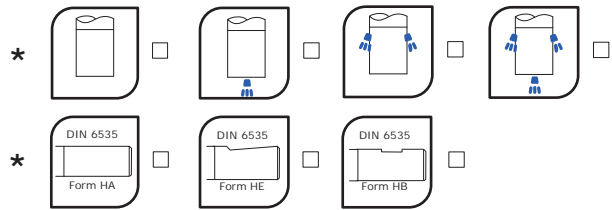
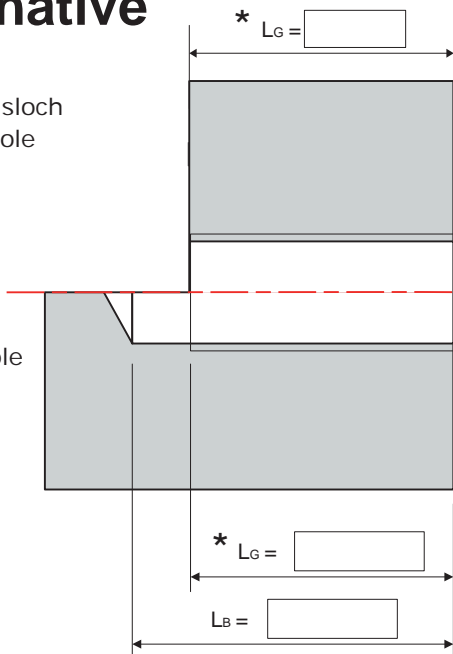

* Schneiden / Flutes:

* Beschichtung /
Coating:

* Bearbeitetes Material/
Material to be machined

Allgemeintoleranzen / General Tolerances:

Durchmesser $\pm 0,01$

Längen $\pm 0,1$

Winkel $\pm 1^\circ$

Diameters ± 0.01

Lengths ± 0.1

Angles $\pm 1^\circ$

* **Muss-Angaben / Compulsory Fields**



Spanabhebende Präzisionswerkzeuge GmbH
G.-Daimler-Str. 10 DE-35423 GERMANY
Tel: +49 6404 6634-0
Fax: +49 6404 6634-21
E-Mail: order@sppw.de

**Sonder
Special**

**Fas-Gewindefräser aus VHM
Carbide Thread & Chamfer Mills**

Firma / Company: _____

Tel.: +____ (____) _____ - _____

Kontakt / Contact: _____

Fax.: +____ (____) _____ - _____

Abteilung / Department: _____

E-Mail: _____ @ _____

Datum / Date: _____

Land / Country: _____

Menge / Quantity: _____ / _____ / _____

Gewünschter Termin /
Delivery Deadline: _____

* Steigung / TPI

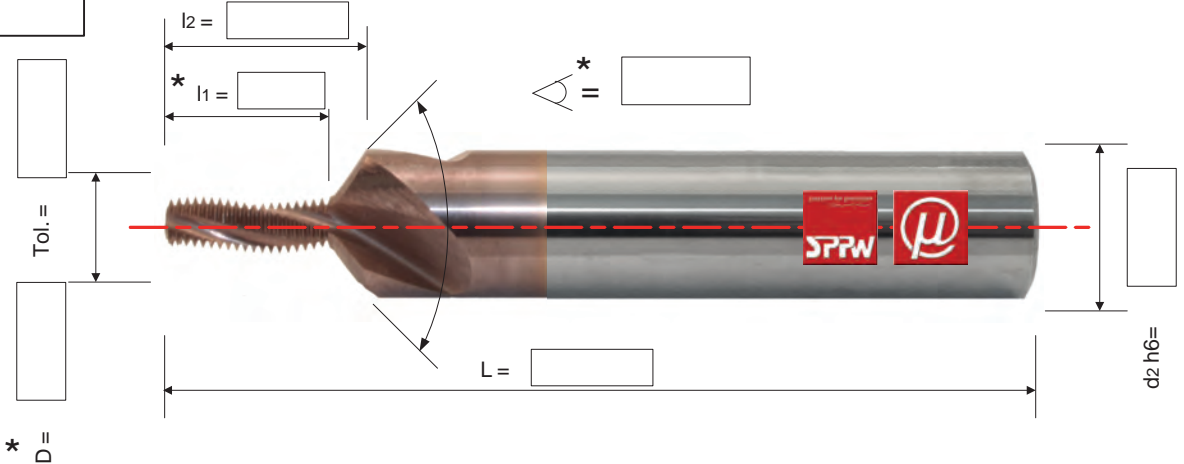

Alternative

Durchgangsloch
Through Hole

Grundloch
Ground Hole

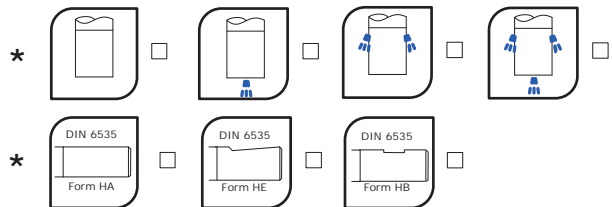
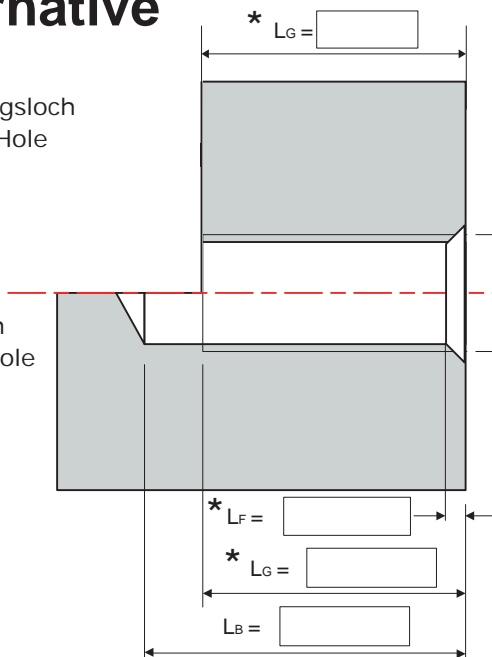

* Schneiden / Flutes:

* Beschichtung /
Coating:

* Bearbeitetes Material/
Material to be machined

Allgemeintoleranzen / General Tolerances:

Durchmesser ± 0,01

Längen ± 0,1

Winkel ± 1°

Diameters ± 0.01

Lengths ± 0.1

Angles ± 1°

* Muss-Angaben / Compulsory Fields



Spanabhebende Präzisionswerkzeuge GmbH
G.-Daimler-Str. 10 DE-35423 GERMANY
Tel: +49 6404 6634-0
Fax: +49 6404 6634-21
E-Mail: order@sppw.de

**Sonder
Special**

**Bohrgewindefräser aus VHM
Carbide Thread Drill Mills**

Firma / Company: _____

Tel.: +____ (____) _____ - _____

Kontakt / Contact: _____

Fax.: +____ (____) _____ - _____

Abteilung / Department: _____

E-Mail: _____ @ _____

Datum / Date: _____

Land / Country: _____

Menge / Quantity: _____ / _____ / _____

Gewünschter Termin /
Delivery Deadline: _____

* Steigung / TPI

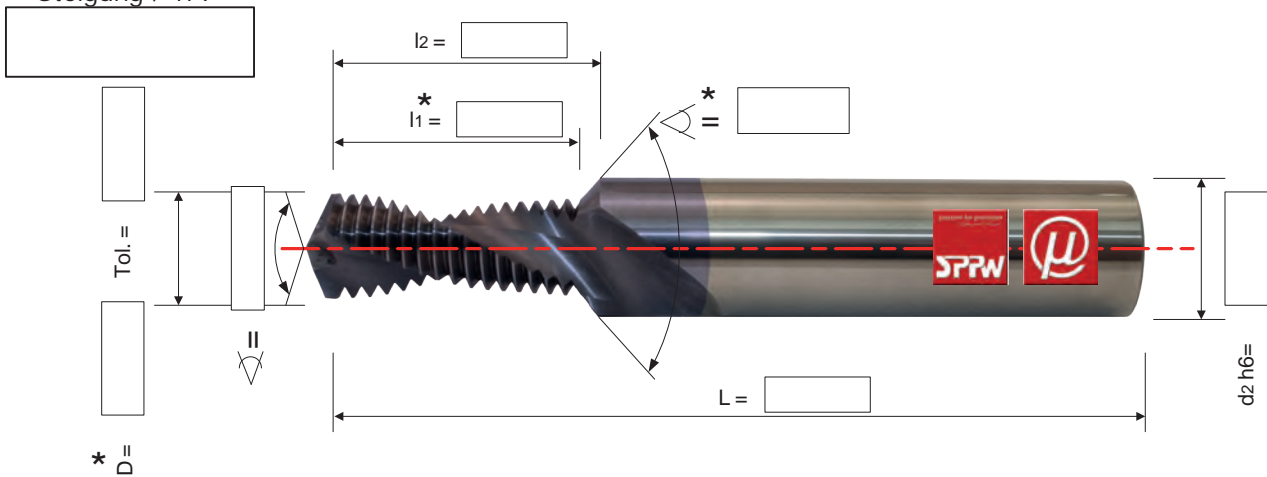

Alternative

Durchgangsloch
Through Hole

Grundloch
Ground Hole

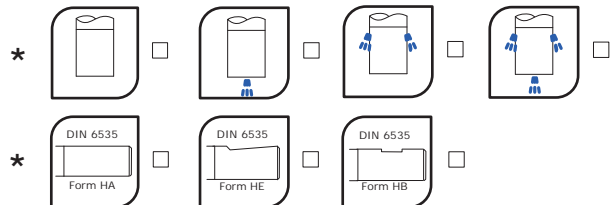
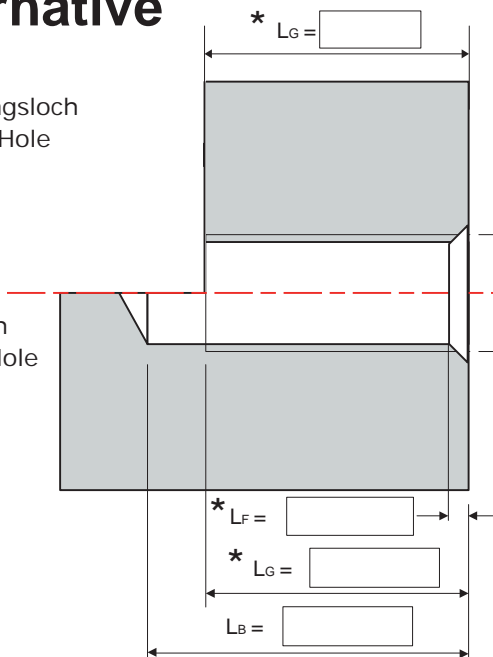

- * Schneiden / Flutes: _____
- * Beschichtung / Coating: _____
- * Bearbeitetes Material / Material to be machined: _____

Allgemeintoleranzen / General Tolerances:

Durchmesser ± 0,01 Längen ± 0,1 Winkel ± 1°
Diameters ± 0.01 Lengths ± 0.1 Angles ± 1°

* Muss-Angaben / Compulsory Fields



Spanabhebende Präzisionswerkzeuge GmbH
G.-Daimler-Str. 10 DE-35423 GERMANY
Tel: +49 6404 6634-0
Fax: +49 6404 6634-21
E-Mail: order@sppw.de

Sonder Special

Firma / Company: _____

Tel.: +____ (____) _____ - _____

Kontakt / Contact: _____

Fax.: +____ (____) _____ - _____

Abteilung / Department: _____

E-Mail: _____ @ _____

Datum / Date: _____

Land / Country: _____

Menge / Quantity: _____ / _____ / _____

Gewünschter Termin /
Delivery Deadline: _____

Sonderprofil / Special Profile

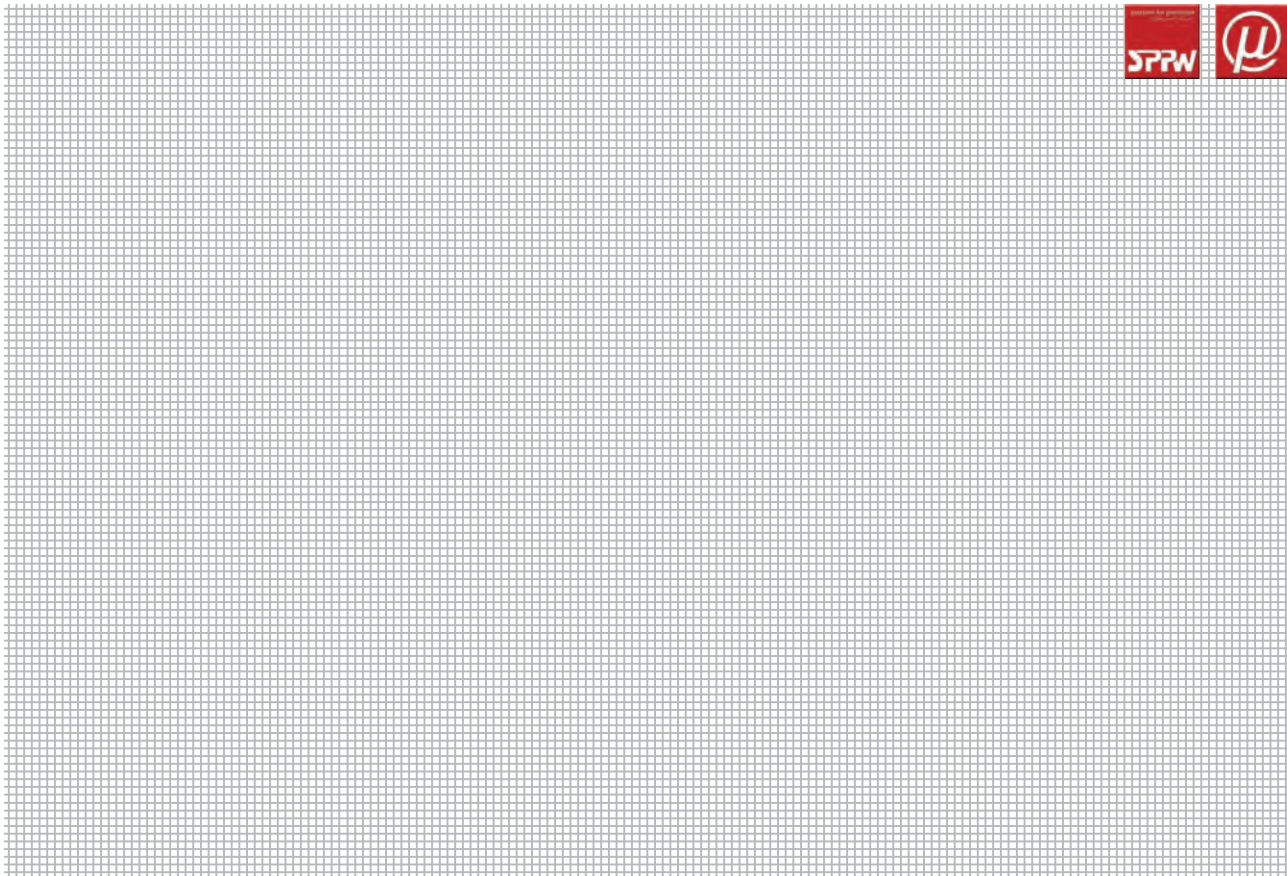

* $\varnothing =$ Stg/TPI = Tol. =

Allgemeintoleranzen / General Tolerances:

Durchmesser $\pm 0,01$

Längen $\pm 0,1$

Winkel $\pm 1^\circ$

Diameters ± 0.01

Lengths ± 0.1

Angles $\pm 1^\circ$

* Schneiden / Flutes:

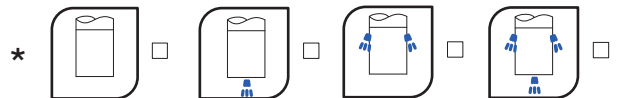

* Beschichtung / Coating:

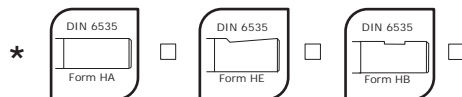

* Bearbeitetes Material /
Material to be machined



Spanabhebende Präzisionswerkzeuge GmbH
G.-Daimler-Str. 10 DE-35423 GERMANY
Tel: +49 6404 6634-0
Fax: +49 6404 6634-21
E-Mail: order@sppw.de

**Sonder
Special**

**Gewindewirbler aus VHM
Carbide Thread Whirling Cutters**

Firma / Company: _____

Tel.: + ____ (____) _____ - ____

Kontakt / Contact: _____

Fax.: + ____ (____) _____ - ____

Abteilung / Department: _____

E-Mail: _____ @ _____

Datum / Date: _____

Land / Country: _____

Menge / Quantity: _____ / _____ / _____

Gewünschter Termin /
Delivery Deadline: _____

* Steigung / TPI

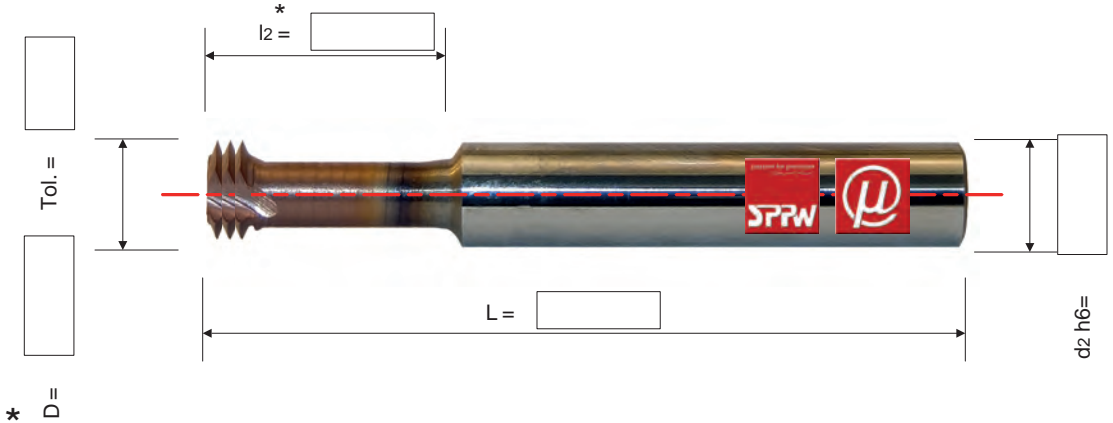

Alternative

Durchgangsloch
Through Hole

Grundloch
Ground Hole

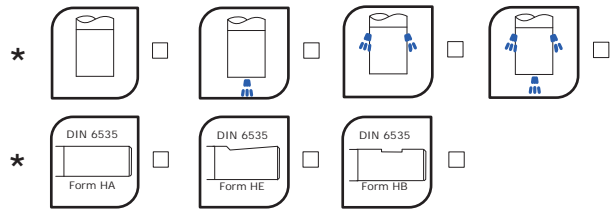
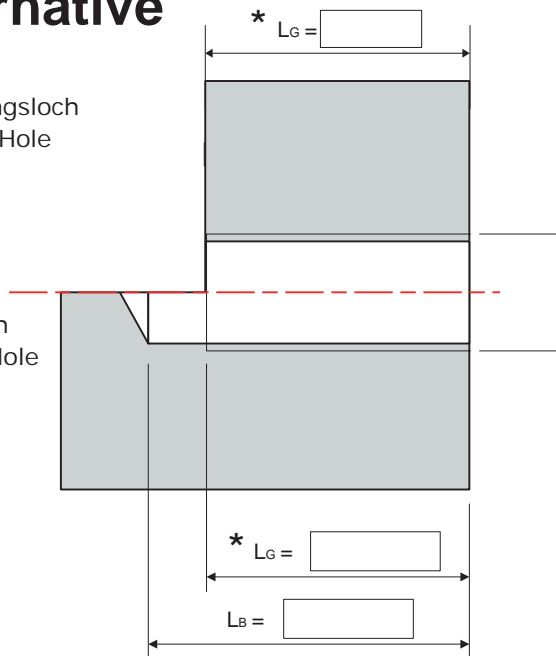

- * Schneiden / Flutes:
- * Beschichtung / Coating:
- * Bearbeitetes Material / Material to be machined:

Allgemeintoleranzen / General Tolerances:

Durchmesser ± 0,01 Längen ± 0,1 Winkel ± 1°
Diameters ± 0.01 Lengths ± 0.1 Angles ± 1°

* **Muss-Angaben / Compulsory Fields**



Spanabhebende Präzisionswerkzeuge GmbH
G.-Daimler-Str. 10 DE-35423 GERMANY
Tel: +49 6404 6634-0
Fax: +49 6404 6634-21
E-Mail: order@sppw.de