



[DE] **Rapid Line**

Fräser für Moderne Werkstoffe

[EN] **Rapid Line**

Milling Cutters for Modern Materials



passion for precision

[Leidenschaft für Präzision]

I

Microfräser VHM

Carbide Micro End Mills

Art.No./Page

<input type="checkbox"/>	<input type="checkbox"/>		VHM	poliert	z:1	DIN 6535HA	micro 2-3xØ	sharp	668 515 Seite I 1
--------------------------	--------------------------	---	-----	---------	-----	------------	-------------	-------	-----------------------------

Einzahnfräser VHM

Carbide Single Flute End Mills

Art.No./Page

<input type="checkbox"/>	<input type="checkbox"/>		VHM	poliert	W 30°	z:1	DIN 6535HA	HAWK	750 074 Seite I 2
--------------------------	--------------------------	---	-----	---------	-------	-----	------------	------	-----------------------------

<input type="checkbox"/>	<input type="checkbox"/>		VHM	Dia HC	W 30°	z:1	DIN 6535HA	HAWK	750 074 HC Seite I 2
--------------------------	--------------------------	---	-----	--------	-------	-----	------------	------	--------------------------------

<input type="checkbox"/>	<input type="checkbox"/>		VHM	poliert	W 25°	z:1	DIN 6535HA		751 100 Seite I 3
--------------------------	--------------------------	---	-----	---------	-------	-----	------------	--	-----------------------------

<input type="checkbox"/>	<input type="checkbox"/>		VHM	poliert	W 25°	z:1	DIN 6535HA		751 110 Seite I 4
--------------------------	--------------------------	---	-----	---------	-------	-----	------------	--	-----------------------------

<input type="checkbox"/>	<input type="checkbox"/>		VHM	poliert	W 0°	z:1	DIN 6535HA		751 001 Seite I 5
--------------------------	--------------------------	---	-----	---------	------	-----	------------	--	-----------------------------

<input type="checkbox"/>	<input type="checkbox"/>		VHM	poliert	W 25°	z:1	DIN 6535HA	Radius	751 105 Seite I 5
--------------------------	--------------------------	---	-----	---------	-------	-----	------------	--------	-----------------------------

<input type="checkbox"/>	<input type="checkbox"/>		VHM	poliert	W 24°	z:1	DIN 6535HA	PLX	750 033 Seite I 6
--------------------------	--------------------------	--	-----	---------	-------	-----	------------	-----	-----------------------------

<input type="checkbox"/>	<input type="checkbox"/>		VHM	poliert	W 24°	z:1	DIN 6535HA	PLX	750 035 Seite I 6
--------------------------	--------------------------	---	-----	---------	-------	-----	------------	-----	-----------------------------

<input type="checkbox"/>	<input type="checkbox"/>		VHM	poliert	W 24°	z:1	DIN 6535HA	L lang PLX	750 037 Seite I 6
--------------------------	--------------------------	---	-----	---------	-------	-----	------------	------------	-----------------------------

Hochleistungsfräser VHM

Carbide High Performance End Mills

Art.No./Page

<input type="checkbox"/>	<input type="checkbox"/>		VHM	poliert	W 40°	z:2	DIN 6535HA	ER Torus	751 024 Seite I 7
--------------------------	--------------------------	---	-----	---------	-------	-----	------------	----------	-----------------------------

<input type="checkbox"/>	<input type="checkbox"/>		VHM	Alu Cut	W 40°	z:2	DIN 6535HA	ER Torus	751 024 A Seite I 7
--------------------------	--------------------------	---	-----	---------	-------	-----	------------	----------	-------------------------------

<input type="checkbox"/>	<input type="checkbox"/>		VHM	poliert	W 40°	z:2	DIN 6535HA	Radius	751 025 Seite I 8
--------------------------	--------------------------	---	-----	---------	-------	-----	------------	--------	-----------------------------



<input type="checkbox"/>	<input type="checkbox"/>		VHM	Alu Cut	W 40°	z:2	DIN 6535HA	ER Torus	751 025 A Seite I 8
--------------------------	--------------------------	---	-----	---------	-------	-----	------------	----------	-------------------------------

<input type="checkbox"/>	<input type="checkbox"/>		VHM	poliert	DIN 6527L	UT 45°	z:3	DIN 6535HA	751 032 Seite I 9
--------------------------	--------------------------	---	-----	---------	-----------	--------	-----	------------	-----------------------------

<input type="checkbox"/>	<input type="checkbox"/>		VHM	Z Cut	DIN 6527L	UT 45°	z:3	DIN 6535HA	757 032 Seite I 9
--------------------------	--------------------------	---	-----	-------	-----------	--------	-----	------------	-----------------------------

<input type="checkbox"/>	<input type="checkbox"/>		VHM	poliert	UT 37/40	z:3	DIN 6535HA	ER Torus	751 150 Seite I 10
--------------------------	--------------------------	---	-----	---------	----------	-----	------------	----------	------------------------------











<input type="checkbox"/>	<input type="checkbox"/>		VHM	poliert	UT 37/40	z:3	DIN 6535HA	L lang ER Torus	751 151 Seite I 10
--------------------------	--------------------------	---	-----	---------	----------	-----	------------	-----------------	------------------------------

● ●		VHM	poliert	HPC-W 40°	z:3	DIN 6535HA	751 653 Seite 11
● ●		VHM	poliert	HPC WR	z:3	DIN 6535HA	751 683 Seite 11

Schaftfräser VHM mit 2 und 3 Schneiden

Carbide End Mills with 2 or 3 flutes





Art.No./Page

● ●		VHM	poliert	W 30°	z:2	DIN 6535HA	751 023 Seite 12
● ●		VHM	poliert	W 40°	z:2	DIN 6535HA	751 020 Seite 12
● ●		VHM	poliert	W 0°	z:2	DIN 6535HA	751 000 Seite 13
● ●		VHM	poliert	W 30°	z:2	DIN 6535HA	751 040 Seite 13
● ●		VHM	poliert	W +30 -30	z:2	DIN 6535HA	751 027 Seite 14
● ●		VHM	poliert	UT 30°	z:3	DIN 6535HA	751 030 Seite 15
● ●		VHM	poliert	W 0°	z:3	DIN 6535HA	751 010 Seite 15
● ●		VHM	poliert	W 30°	z:3	DIN 6535HA	751 050 Seite 16
● ●		VHM	poliert	W 20°	z:3	DIN 6535HA	751 031 Seite 16
● ●		VHM	poliert	W 30°	z:3	DIN 6535HA	751 034 Seite 17
● ●		VHM	poliert	W 30°	z:3	DIN 6535HA	751 035 Seite 17

Fräser für spezielle Anwendungen

Carbide End Mills for Special Applications

Art.No./Page

●		VHM	poliert	AFRP 0°	z:2 1+1	DIN 6535HA	751 190 Seite 18
●		VHM	poliert	AFRP 0°	z:4 2+2	DIN 6535HA	751 194 Seite 18
● ●		VHM	poliert	W 20°	90°	z:2 DIN 6535HA	751 902 Seite 19
● ●		VHM	poliert	W 0°	90°	z: 2-4 DIN 6535HA	751 900 Seite 19

Fräser - Waben-Verbundwerkstoffe

Carbide End Mills for Honeycomb

Art.No./Page

○ ● ●		VHM	poliert	W 50°	z: multi	DIN 6535HA	751 077 Seite 20
-------	---	-----	---------	----------	-------------	---------------	------------------------------

				VHM	poliert	Set modulR	z: multi	DIN 6535HA	Honey Comb	751 078 Seite 20
				Teile parts	Honey Comb					751 079 Seite 21

Fräser - Faser-Verbundwerkstoffe

Carbide End Mills for FRP

Art.No./Page

		VHM	Dia HC	W +20 -20	DIN 6535HA	CFK carbone	790 070 HC Seite 22
		VHM	Dia HC	WX 0°	Multi	DIN 6535HA	CFK carbone
		VHM	Dia HC	WX -30°	Multi	DIN 6535HA	CFK carbone
		VHM	Dia HC	WX 30°	DIN 6535HA	CFK carbone	790 065 HC Seite 23
		VHM	Dia HC	W +20 -20	Multi	DIN 6535HA	GFK CFK
		VHM	DIA Plus	W +20 -20	Multi	DIN 6535HA	GFK CFK
		VHM	poliert	W 0°	z:5	DIN 6535HA	GFK CFK
		VHM	Dia HC	W 0°	z:5	DIN 6535HA	GFK CFK
		VHM	poliert	W 10°	z:6	DIN 6535HA	GFK CFK
		VHM	Dia HC	W 10°	z:6	DIN 6535HA	GFK CFK

Pyramidverzahnte Fräser VHM

Carbide Pyramide Cut End Mills

Art.No./Page

		VHM	Dia HC	WX 30°	Multi	DIN 6535HA	GFK CFK	751 080 HC Seite 27
		VHM	poliert	WX 30°	Multi	DIN 6535HA	GFK CFK	751 080 Seite 28
		VHM	Dia HC	WX 30°	Multi	DIN 6535HA	GFK CFK	751 070 HC Seite 29
		VHM	poliert	WX 30°	Multi	DIN 6535HA	GFK CFK	751 070 Seite 30
		VHM	Dia HC	WX 30°	Multi	DIN 6535HA	GFK CFK	751 090 HC Seite 31
		VHM	poliert	WX 30°	Multi	DIN 6535HA	GFK CFK	751 090 Seite 32
		VHM	Dia HC	WX 30°	Multi	DIN 6535HA	GFK CFK	751 085 HC Seite 33



751 085
Seite | 34

Fräser - Grafitwerkstoffe

Carbide End Mills for Graphite

Art.No./Page



792 644
Seite | 35



792 645
Seite | 35

Fräser für Leichtlegierungen HSS-E

HSS-E End Mills for NF-Metals

Art.No./Page



551 100
Seite | 36



552 480
Seite | 37



552 580
Seite | 37

— INFO —

MKD (Monokristalliner Diamant)

Durch seine Gitterstruktur besitzt MKD eine sehr hohe Härte. Zudem wird monokristalliner Diamant nicht durch eine Bindephase an der Schneide unterbrochen. Daher eignet sich MKD sehr gut zum Herstellen hochpräziser Oberflächen bei der Glanzbearbeitung und hochgenauen Bauteilen.

- Extrem lange Standzeiten auch in abrasiven Werkstoffen
- Hohe Schnittgeschwindigkeiten und Vorschübe
- Endbearbeitung mit besten Oberflächengüten und Genauigkeiten

MKD-bestückte Werkzeuge sind hervorragend für das Finishing von NE-Metallen, Edelmetallen und transparenten Kunststoffen wie PMMA und PC geeignet.

PCD (Polycrystalline Diamond)

Due to its grid structure, MKD has a very high hardness. In addition, monocrystalline diamond is not interrupted by a binder phase at the cutting edge. Therefore, MKD is very suitable for producing high-precision surfaces in polishing and high-precision components.

- Extremely long tool life even in abrasive materials.
- High cutting speeds and feed rates.
- Finishing with the best surface finishes and accuracies.

MKD-tipped tools are excellent for finishing non-ferrous metals, precious metals and transparent plastics such as PMMA and PC.





- Für Leichtlegierung und Kunststoff
- Kurze, stabile Ausführung
- Schneidenlänge 3xØ
- Verstärkter Zylinderschaft Form HA
- Zentrumschnitt 1 Schneide über Mitte
- Oberfläche poliert

- For all light alloys and plastics
- Short series with high rigidity
- Cutting length 3xØ
- Reinforced cylindrical shank form HA
- Center cutting
- Polished finish

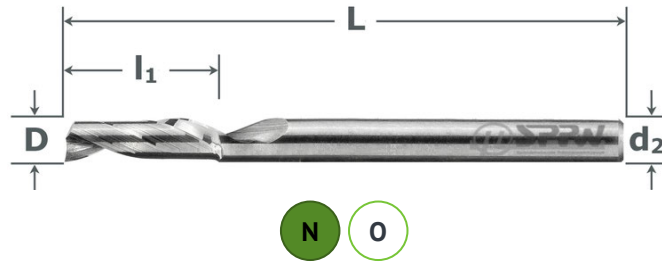

VHM	poliert
z:1	DIN 6535HA
micro 2-3xØ	sharp

ØD h10	Ød2 h5	L	l1	z	Art. No.	Stk/pce Euro	ØD h10	Ød2 h5	L	l1	z	Art. No.	Stk/pce Euro
0,5	3	39	1,5	1	6685150050	16,30	1,5	3	39	4	1	6685150150	17,70
0,6	3	39	1,5	1	6685150060	16,30	1,6	3	39	4	1	6685150160	18,60
0,8	3	39	2	1	6685150080	17,70	1,8	3	39	5	1	6685150180	18,60
1	3	39	3	1	6685150100	15,90	2	3	39	5	1	6685150200	17,70
1,2	3	39	4	1	6685150120	16,30	2,5	3	39	7	1	6685150250	19,50
1,4	3	39	4	1	6685150140	17,70	3	3	39	10	1	6685150300	21,50

INFO

Microfräser ab Ø0,05 mm in 1/10 steigend im Kapitel H "Micro Fräsen"

- Schneidenlängen 0,75xØ - 1,5xØ - 3xØ - 5xØ - 8xØ
- Nutzlängen mit Freistellung bis 30 mm
- Nutfräser, Radiusfräser und Torusfräser

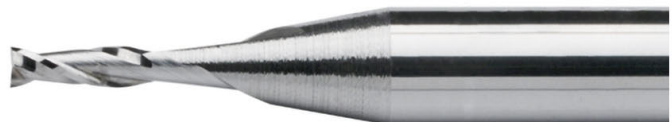

Micro End Mills from Ø0,05mm in 1/10 increments in chapter H "Micro Milling"

- Cutting lengths 0,75xØ - 1,5xØ - 3xØ - 5xØ - 8xØ
- Extended usable lengths up to 30 mm
- Flat nose, ball nose or corner radius

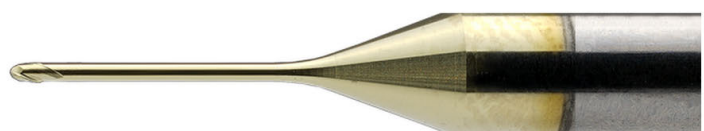

750 074

HSC-Einzahnfräser VHM HAWK

Carbide HSC Single Flute End Mills HAWK



- Zur Bearbeitung von Alu-Profilen
- Spezielle Schneide zum Eintauchen
- Extrem scharfe Schneidkanten
- Rechtsschneidend mit Rechtsspirale
- Oberfläche poliert

- For working aluminum profiles
- Relieved cutting edges for diving
- Extremely sharp cutting edges
- Right hand helix, right hand cutting
- Polished finish

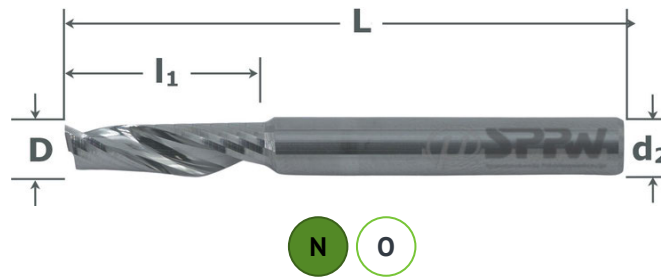

VHM	poliert
W 30°	z:1
DIN 6535HA	HAWK

ØD h10	Ød2 h6	L	l1	z	Art. No.	Stk/pce Euro	ØD h10	Ød2 h6	L	l1	z	Art. No.	Stk/pce Euro
3	3	38	10	1	7500740300	11,80	6	6	50	11	1	7500740611	19,50
4	4	50	12	1	7500740400	13,80	8	8	63	24	1	7500740800	31,70
5	5	50	16	1	7500740500	17,00	8	8	57	15	1	7500740815	31,70
5	5	50	11	1	7500740511	17,70	10	10	72	30	1	7500741000	52,90
6	6	57	20	1	7500740600	19,60							

750 074 HC

HSC-Einzahnfräser VHM+Dia.HC HAWK

Carbide HSC Single Flute End Mills+Dia.HC HAWK



- Zur Bearbeitung von Alu-Profilen
- Spezielle Schneide zum Eintauchen
- Extrem scharfe Schneidkanten
- Rechtsschneidend mit Rechtsspirale
- Oberfläche Dia.HC beschichtet

- For working aluminum profiles
- Relieved cutting edges for diving
- Extremely sharp cutting edges
- Right hand helix, right hand cutting
- With Dia.HC coating

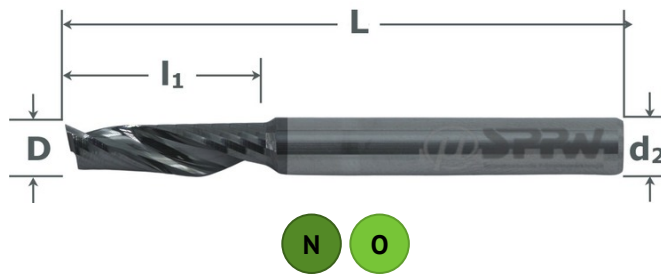

VHM	Dia HC
W 30°	z:1
DIN 6535HA	HAWK

ØD h10	Ød2 h6	L	l1	z	Art. No.	Stk/pce Euro	ØD h10	Ød2 h6	L	l1	z	Art. No.	Stk/pce Euro
3	3	38	10	1	7500740300HC	16,40	6	6	50	11	1	7500740611HC	25,40
4	4	50	12	1	7500740400HC	18,90	8	8	63	24	1	7500740800HC	38,30
5	5	50	16	1	7500740500HC	24,90	8	8	57	15	1	7500740815HC	38,30
5	5	50	11	1	7500740511HC	24,90	8	10	72	30	1	7500741000HC	59,50
6	6	57	20	1	7500740600HC	25,40							

— INFO —**Hawk (Habichtsschnabel)**

Hawk-Einzahnfräser zeichnen sich durch eine sehr scharfe, freigeschliffene Stirnschneide aus und eignen sich aufgrund dieses Freischliffs besonders zum Bohren und anschließendem Besäumen von Aluminium-Vollmaterial und Profilen. Sie sind auch mit Dia.HC Beschichtung erhältlich.

Hawk (Beak)

Hawk single flute cutters have a very sharp, relief-ground frontal cutting edge. They are particularly suitable for drilling and subsequent trimming in aluminum material. They are also available with Dia.HC coating for longer tool life and improved vibration characteristics.

751 100

HSC-Einzahnfräser VHM Rechtsdrall
Carbide HSC Single Flute End Mills Right Hand Helix



- Leichtlegierungen und Kunststoffe
- Rechtsschneidend mit Rechtsspirale
- Zentrumschnitt zum Tauchen
- Extrem scharfe Schneidkanten
- Oberfläche poliert
- Light alloys and plastics
- Right hand helix, right hand cutting
- Center cutting for plunging
- Extremely sharp cutting edges
- Polished finish

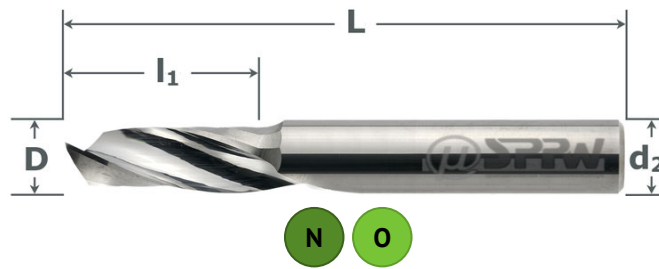

VHM	poliert
W 25°	z:1
DIN 6535HA	

ØD h10	Ød2 h6	L	l1	z	Art. No.	Stk/pce Euro
2	2	40	10	1	7511000200	10,90
3	3	40	12	1	7511000300	11,60
3	6	60	15	1	7511000300L	23,40
4	4	40	15	1	7511000400	14,10
4	6	75	20	1	7511000400L	29,60
5	5	50	16	1	7511000500	18,10
5	6	75	28	1	7511000500L	31,50
6	6	60	20	1	7511000600	20,70
6	6	75	35	1	7511000600L	31,50

ØD h10	Ød2 h6	L	l1	z	Art. No.	Stk/pce Euro
8	8	63	22	1	7511000800	33,70
8	8	100	45	1	7511000800L	62,10
10	10	72	25	1	7511001000	50,70
10	10	100	55	1	7511001000L	88,20
12	12	83	30	1	7511001200	67,20
14	14	83	30	1	7511001400	100,70
16	16	92	35	1	7511001600	142,60
20	20	104	40	1	7511002000	191,90

Schaft 6 h6 - shank 6 mm

ØD h10	Ød2 h6	L	l1	z	Art. No.	Stk/pce Euro
1	6	50	4	1	751100S010601	20,90
2	6	50	6	1	751100S020601	20,90
2	6	50	20	1	751100S020602	23,30
3	6	50	11	1	751100S030601	20,90
3	6	50	22	1	751100S030602	23,90

ØD h10	Ød2 h6	L	l1	z	Art. No.	Stk/pce Euro
4	6	50	14	1	751100S040601	24,90
4	6	50	22	1	751100S040602	25,90
5	6	50	22	1	751100S050601	25,90
6	6	50	22	1	751100S060601	25,90
8	6	75	32	1	751100S080601	53,10

— INFO



Linksspirale vs. Rechtsspirale (Linksdrall der Spannut - Fräser Rechtsschneidend)

Bei einer Linksspirale werden die Späne nach unten in Richtung Werkstück abgeführt. Daher wird das Werkstück bei der Bearbeitung angedrückt, was speziell bei Aufspannungen mit geringer Haltekraft positiv ist. Bei der Bearbeitung von Werkstücken, die zum Ausreißen neigen, lassen sich bessere Oberflächen erzielen. Allerdings ist der Materialabtrag pro Durchgang geringer als bei Fräsern mit Rechtsspirale.

Left-Hand Helix vs. Right-Hand Helix (left-hand twist of the flute - cutter right-hand cutting)

With a left-hand helix, the chips are discharged downwards in the direction of the workpiece. The workpiece is pressed down during machining, which is especially positive for setups with low holding force. Better surfaces can be achieved when machining workpieces that tend to tear out. However, the material removal per pass is lower than with right-hand helix milling cutters.

751 110

HSC-Einzahnfräser VHM Linksdraht Carbide HSC Single Flute End Mills Left Hand Helix



- Leichtlegierungen und Kunststoffe
- Rechtsschneidend mit Linksspirale
- Spanauswurf nach unten
- Extrem scharfe Schneidkanten
- Oberfläche poliert
- Light alloys and plastics
- Left hand helix, right hand cutting
- Extremely sharp cutting edges
- Down-Cut
- Polished finish

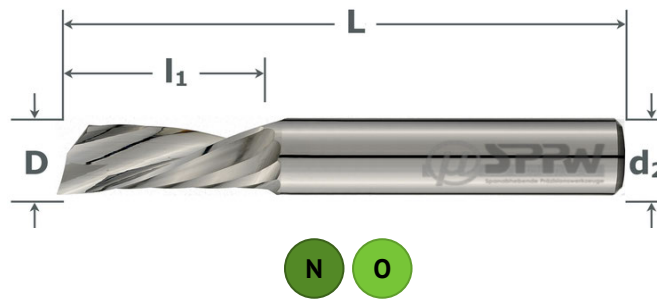

VHM	poliert
W 25°	z:1
DIN 6535HA	

ØD h10	Ød2 h6	L	l1	z	Art. No.	Stk/pce Euro	ØD h10	Ød2 h6	L	l1	z	Art. No.	Stk/pce Euro
2	2	40	10	1	7511100200	10,90	10	10	72	25	1	7511101000	50,70
3	3	40	12	1	7511100300	11,60	12	12	83	30	1	7511101200	67,20
4	4	40	15	1	7511100400	14,10	14	14	83	30	1	7511101400	100,70
5	5	50	16	1	7511100500	18,10	16	16	92	35	1	7511101600	142,60
6	6	60	20	1	7511100600	20,70	20	20	104	40	1	7511102000	191,90
8	8	63	22	1	7511100800	33,70							

Schaft 6 h6 - shank 6 mm

ØD h10	Ød2 h6	L	l1	z	Art. No.	Stk/pce Euro	ØD h10	Ød2 h6	L	l1	z	Art. No.	Stk/pce Euro
1	6	50	4	1	751110S010601	20,90	4	6	50	14	1	751110S040601	24,90
2	6	50	6	1	751110S020601	20,90	4	6	50	22	1	751110S040602	25,90
2	6	50	20	1	751110S020602	23,30	5	6	50	22	1	751110S050601	25,90
3	6	50	11	1	751110S030601	20,90	6	6	50	22	1	751110S060601	25,90
3	6	50	22	1	751110S030602	23,90	8	6	75	32	1	751110S060801	53,10

— INFO —



Rapid Line Fräser Start-Set 10 St / Alu-Kunststoff-Holz 751.111-0011

- 751.100 HSC-Einzahnfräser VHM / W25° Ø3 und Ø6
- 751.110 HSC-Einzahnfräser VHM / WL 25° Ø3 und Ø6
- 751.023 HSC-Schaftfräser VHM / W30° Ø3 und Ø6
- 751.030 HPC-Fräser VHM - UT30° / Schutzfase Ø6
- 751.902 Faskant-Umfangfräser VHM 90° / N20° Ø6
- 751.025 HSC-Radiusfräser VHM / W40° Ø6
- 751.000 HSC-Konturfräser VHM - gerade / W0° Ø6



— INFO —



Einzahnfräser Start-Set 4 St aus VHM / Acryl 751.111-0006

- 750.035 HSC-Einzahnfräser VHM ACRYL Ø4
- 750.033 HSC-Einzahnfräser VHM ACRYL Ø6
- 750.037 HSC-Einzahnfräser VHM ACRYL Ø8
- 750.033 HSC-Einzahnfräser VHM ACRYL Ø10



751 001

HSC-Konturfräser VHM 1 Schneide Geradegenutet Carbide HSC Contouring End Mills 1 Flute Straight Flute



- Leichtlegierungen, Kunststoffe
- Blech, Platten, dünnwandiges Material
- Gerade genutet mit Zentrumschnitt
- Keine Zugkräfte am Werkstück
- Großer Spanraum, leichte Spanabfuhr
- Oberfläche poliert

- Light alloys, plastic, thin materials
- Straight flutes center cutting
- No drag or push on the workpiece
- Large chip space, easy chip removal
- Polished finish

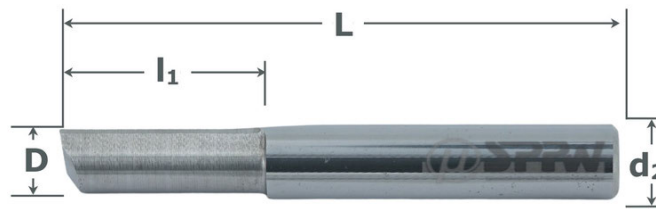

VHM	poliert
W 0°	z:1
DIN 6535HA	

ØD h10	Ød2 h6	L	l1	z	Art. No.	Stk/pce Euro	ØD h10	Ød2 h6	L	l1	z	Art. No.	Stk/pce Euro
1,5	3	40	6	1	7510010156	16,30	6	6	60	20	1	7510010600	20,70
2	3	40	6	1	7510010203	15,30	6	6	75	35	1	7510010600L	31,50
2	6	60	10	1	7510010206L	22,20	8	8	63	22	1	7510010800	33,70
3	3	40	12	1	7510010300	11,60	8	8	100	40	1	7510010800L	55,20
3	6	60	15	1	7510010306L	23,40	10	10	72	25	1	7510011000	50,70
4	6	60	15	1	7510010406	23,40	10	10	100	55	1	7510011000L	88,20
4	6	75	20	1	7510010406L	29,60	12	12	83	30	1	7510011200	67,20
5	6	60	16	1	7510010506	23,40							

751 105

HSC-Radius-Einzahnfräser VHM Carbide HSC Single Flute Radius End Mills



- Leichtlegierungen und Kunststoffe
- Rechtsschneidend mit Rechtsspirale
- Stirnradius für Kopierarbeiten
- Extrem scharfe Schneidkanten
- Oberfläche poliert

- Light alloys and plastics
- Right hand helix, right hand cutting
- Radius for copying operations
- Extremely sharp cutting edges
- Polished finish

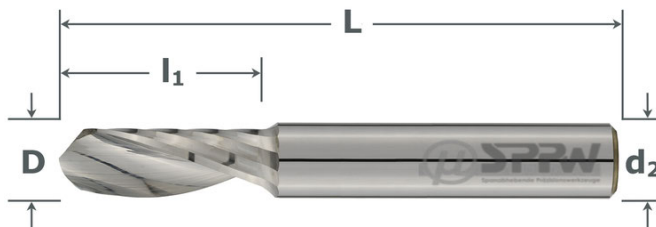

VHM	poliert
W 25°	z:1
DIN 6535HA	
Radius	

ØD h10	Ød2 h6	L	l1	z	Art. No.	Stk/pce Euro	ØD h10	Ød2 h6	L	l1	z	Art. No.	Stk/pce Euro
2	3	40	6	1	7511050203	21,00	6	6	60	20	1	7511050600	27,50
2	6	60	10	1	7511050206	25,90	6	6	75	35	1	7511050601	40,10
3	3	40	12	1	7511050300	16,00	8	8	63	22	1	7511050800	42,90
3	6	60	12	1	7511050306	25,90	8	8	100	40	1	7511050801	72,40
4	4	40	15	1	7511050400	18,60	10	10	72	25	1	7511051000	61,90
4	6	60	15	1	7511050406	27,30	10	10	100	55	1	7511051001	103,20
5	5	50	16	1	7511050500	23,90	12	12	83	30	1	7511051200	82,00
5	6	60	16	1	7511050506	27,30							



- Für hochtransparente Oberflächen
- Acryl, Plexiglas, Polycarbonat
- Extrem scharfe Schneidkanten
- Oberfläche poliert
- For highly transparent surfaces
- Acrylic, PMMA, polycarbonate
- Extremely sharp cutting edges
- Polished finish

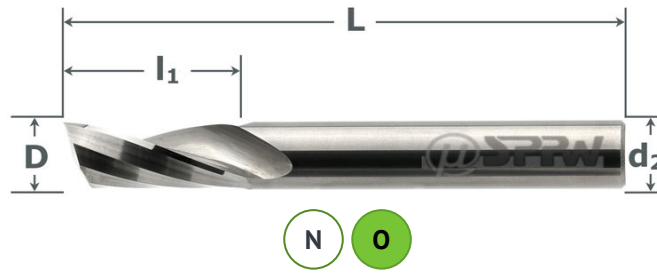

VHM	poliert
W 24°	z:1
DIN 6535HA	PLX

750033 - kurz | short version

ØD h10	Ød2 h6	L	l1	z	Art. No.	Stk/pce Euro
3	3	38	8	1	7500330300	16,60
4	4	50	10	1	7500330400	16,70
5	5	50	12	1	7500330500	20,90
6	6	57	16	1	7500330600	23,60

ØD h10	Ød2 h6	L	l1	z	Art. No.	Stk/pce Euro
8	8	63	20	1	7500330800	37,30
10	10	72	24	1	7500331001	65,00
12	12	83	28	1	7500331201	76,40

750035 - mittel | medium version

ØD h10	Ød2 h6	L	l1	z	Art. No.	Stk/pce Euro
2	2	38	8	1	7500350200	18,40
3	3	38	12	1	7500350300	19,70
4	4	50	14	1	7500350400	19,80
5	5	60	18	1	7500350500	24,70

ØD h10	Ød2 h6	L	l1	z	Art. No.	Stk/pce Euro
6	6	60	22	1	7500350600	27,80
8	8	75	32	1	7500350800	44,00
10	10	75	35	1	7500351001	78,00
12	12	83	40	1	7500351201	89,40

750037 - lang | long version

ØD h10	Ød2 h6	L	l1	z	Art. No.	Stk/pce Euro
3	3	50	16	1	7500370300	23,70
4	4	60	18	1	7500370400	23,80
5	5	60	25	1	7500370500	29,50

ØD h10	Ød2 h6	L	l1	z	Art. No.	Stk/pce Euro
6	6	75	32	1	7500370600	33,50
8	8	80	42	1	7500370800	53,50

INFO

Fräser für hochtransparente Oberflächen

PLX-Shine-Fräser sind speziell zur Bearbeitung von transparenten Kunststoffen (Acryl) ausgelegt. Durch die "ultrageläppte" Spannuten, die besondere Geometrie und die geläpften Schneidkanten weisen PLX-Shine Fräser herausragende Eigenschaften auf.

- Spezielle Kantenpräparation = optimierte Spanbildung
- Polierte Spannuten = bessere Spanabfuhr

Hochtransparente Fräsoberflächen, nachträgliches Polieren kann entfallen.

Milling Cutters for Highly Transparent Surfaces

PLX-Shine cutters are specially designed for machining transparent plastics (e.g. acrylic). Due to the "ultra-polished" flutes, the special cutting geometry and the honed cutting edges, PLX-Shine cutters have outstanding machining properties.

- Special edge preparation = optimized chipping
- Polished flutes = improved chip evacuation

The milled surfaces are highly transparent, no subsequent polishing required.



751 024

HSC-Torusfräser VHM 2 Schneiden
Carbide Torical HSC End Mills 2 Flutes



- HSC-Schrupp-/Schlichtfräser
- Langspanende Werkstoffe, NE-Metalle
- 40° Spirale mit großen Spanräumen
- Freistellung nach der Schneide
- Oberfläche poliert
- HSC roughing and finishing
- Long chipping materials, NF-metals
- 40° helix with large chip space
- Back clearance after cutting edge
- Polished finish

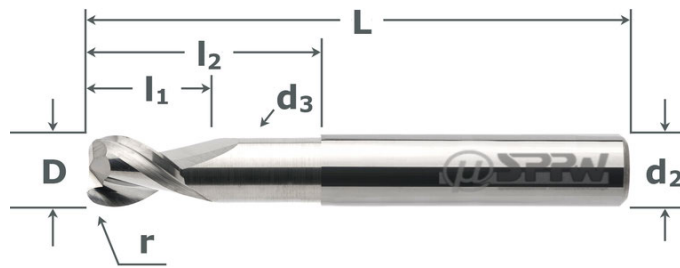

VHM	poliert
W 40°	z:2
DIN 6535HA	ER Torus



ØD h10	Ød2 h6	L	l1	l2	z	r Radius	Ød3	Art. No.	Stk/pce Euro
2	6	57	4	6	2	0,5	1,8	7510240205	28,20
3	6	57	5	9	2	0,5	2,8	7510240305	28,20
3	6	100	6	50	2	0,5	2,8	7510240305L	36,80
4	6	57	6	12	2	0,5	3,7	7510240405	28,20
4	6	100	8	50	2	0,5	3,7	7510240405L	36,80
5	6	57	7	15	2	0,5	4,6	7510240505	28,20
5	6	100	10	50	2	0,5	4,6	7510240505L	36,80
6	6	57	8	20	2	1	5,5	7510240610	27,20
6	6	100	12	50	2	1	5,5	7510240610L	34,90
8	8	63	10	26	2	1	7,4	7510240810	37,20
8	8	100	16	50	2	1	7,4	7510240810L	51,50

ØD h10	Ød2 h6	L	l1	l2	z	r Radius	Ød3	Art. No.	Stk/pce Euro
10	10	72	12	31	2	1,5	9,2	7510241015	50,70
10	10	120	20	70	2	1,5	9,2	7510241015L	76,00
12	12	83	14	37	2	1,5	11	7510241215	70,40
12	12	150	24	100	2	1,5	11	7510241215L	122,50
14	14	83	16	41	2	2	13	7510241420	92,90
14	14	150	28	100	2	2	13	7510241420L	161,90
16	16	92	18	43	2	2	15	7510241620	118,20
16	16	150	32	100	2	2	15	7510241620L	194,30
20	20	150	40	100	2	2,5	19	7510242000L	282,90
20	20	104	22	53	2	2,5	19	7510242025	185,80

Alu.Cut Beschichtung | coating

ØD h10	Ød2 h6	L	l1	l2	z	r Radius	Ød3	Art. No.	Stk/pce Euro
2	6	57	4	6	2	0,5	1,8	7510240205A	32,70
3	6	57	5	9	2	0,5	2,8	7510240305A	32,70
3	6	100	6	50	2	0,5	2,8	7510240305LA	42,60
4	6	57	6	12	2	0,5	3,7	7510240405A	34,10
4	6	100	8	50	2	0,5	3,7	7510240405LA	42,60
5	6	57	7	15	2	0,5	4,6	7510240505A	33,90
5	6	100	10	50	2	0,5	4,6	7510240505LA	43,60
6	6	57	8	20	2	1	5,5	7510240610A	32,90
6	6	100	12	50	2	1	5,5	7510240610LA	41,80
8	8	63	10	26	2	1	7,4	7510240810A	49,70
8	8	100	16	50	2	1	7,4	7510240810LA	64,30

ØD h10	Ød2 h6	L	l1	l2	z	r Radius	Ød3	Art. No.	Stk/pce Euro
10	10	72	12	31	2	1,5	9,2	7510241015A	63,80
10	10	120	20	70	2	1,5	9,2	7510241015LA	89,40
12	12	83	14	37	2	1,5	11	7510241215A	85,60
12	12	150	24	100	2	1,5	11	7510241215LA	138,40
14	14	83	16	41	2	2	13	7510241420A	110,90
14	14	150	28	100	2	2	13	7510241420LA	180,70
16	16	92	18	43	2	2	15	7510241620A	138,30
16	16	150	32	100	2	2	15	7510241620LA	215,30
20	20	150	40	100	2	2,5	19	7510242000LA	308,70
20	20	104	22	53	2	2,5	19	7510242025A	210,30

— INFO —



Kleinstfräser für den Aluminium-Formenbau im Kapitel H " Micro Fräsen"

- Nutfräser
- Torusfräser
- Radiusfräser

Miniature End Mills for Aluminium Moldmaking in chapter H "Micro Milling"

- Slot end mills
- Torical end mills
- Radius end mills

751 025**HSC-Radiusfräser VHM 2 Schneiden**
Carbide HSC Radius End Mills 2 Flutes

- HSC-Schrupp-/Schlichtfräser
- Langspanende Werkstoffe, NE-Metalle
- 40° Spirale mit großen Spanräumen
- Freistellung nach der Schneide
- Oberfläche poliert

- HSC roughing and finishing
- Long chipping materials, NF-metals
- 40° helix with large chip space
- Back clearance after cutting edge
- Polished finish

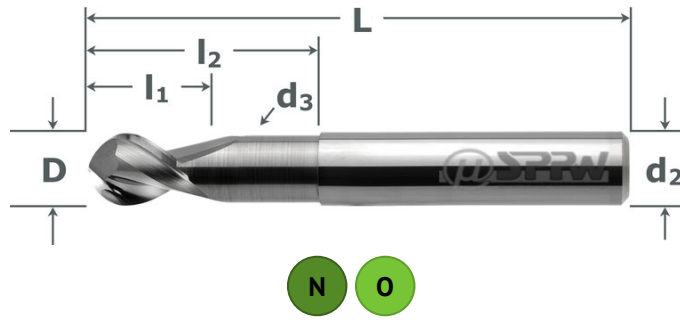

VHM	poliert
W 40°	z:2
DIN 6535HA	Radius



ØD h10	Ød2 h6	L	l1	l2	z	Ød3	Art. No.	Stk/pce Euro
2	6	57	4	6	2	1,8	7510250200	28,20
3	6	57	5	9	2	2,8	7510250300	28,20
3	6	100	6	50	2	2,8	7510250300L	36,80
4	6	57	6	12	2	3,7	7510250400	28,20
4	6	100	8	50	2	3,7	7510250400L	36,80
5	6	57	7	15	2	4,6	7510250500	28,20
5	6	100	10	50	2	4,6	7510250500L	36,80
6	6	57	8	20	2	5,5	7510250600	27,20
6	6	100	12	50	2	5,5	7510250600L	34,90
8	8	63	10	26	2	7,4	7510250800	37,20
8	8	100	16	50	2	7,4	7510250800L	51,50

ØD h10	Ød2 h6	L	l1	l2	z	Ød3	Art. No.	Stk/pce Euro
10	10	72	12	31	2	9,2	7510251000	50,70
10	10	120	20	70	2	9,2	7510251000L	76,00
12	12	83	14	37	2	11	7510251200	70,40
12	12	150	24	100	2	11	7510251200L	122,50
14	14	83	16	41	2	13	7510251400	92,90
14	14	150	28	100	2	13	7510251400L	161,90
16	16	92	18	43	2	15	7510251600	118,20
16	16	150	32	100	2	15	7510251600L	194,30
20	20	104	22	53	2	19	7510252000	185,80
20	20	150	40	100	2	19	7510252000L	282,90

Alu.Cut Beschichtung | coating

ØD h10	Ød2 h6	L	l1	l2	z	Ød3	Art. No.	Stk/pce Euro
2	6	57	4	6	2	1,8	7510250200A	32,70
3	6	57	5	9	2	2,8	7510250300A	33,90
3	6	100	6	50	2	2,8	7510250300LA	43,60
4	6	57	6	12	2	3,7	7510250400A	33,90
4	6	100	8	50	2	3,7	7510250400LA	43,90
5	6	57	7	15	2	4,6	7510250500A	33,90
5	6	100	10	50	2	4,6	7510250500LA	43,60
6	6	57	8	20	2	5,5	7510250600A	33,10
6	6	100	12	50	2	5,5	7510250600LA	41,80
8	8	63	10	26	2	7,4	7510250800A	50,10
8	8	100	16	50	2	7,4	7510250800LA	64,60

ØD h10	Ød2 h6	L	l1	l2	z	Ød3	Art. No.	Stk/pce Euro
10	10	72	12	31	2	9,2	7510251000A	64,20
10	10	120	20	70	2	9,2	7510251000LA	89,40
12	12	83	14	37	2	11	7510251200A	85,60
12	12	150	24	100	2	11	7510251200LA	138,40
14	14	83	16	41	2	13	7510251400A	110,90
14	14	150	28	100	2	13	7510251400LA	180,70
16	16	92	18	43	2	15	7510251600A	138,30
16	16	150	32	100	2	15	7510251600LA	215,30
20	20	104	22	53	2	19	7510252000A	210,30
20	20	150	40	100	2	19	7510252000LA	305,00

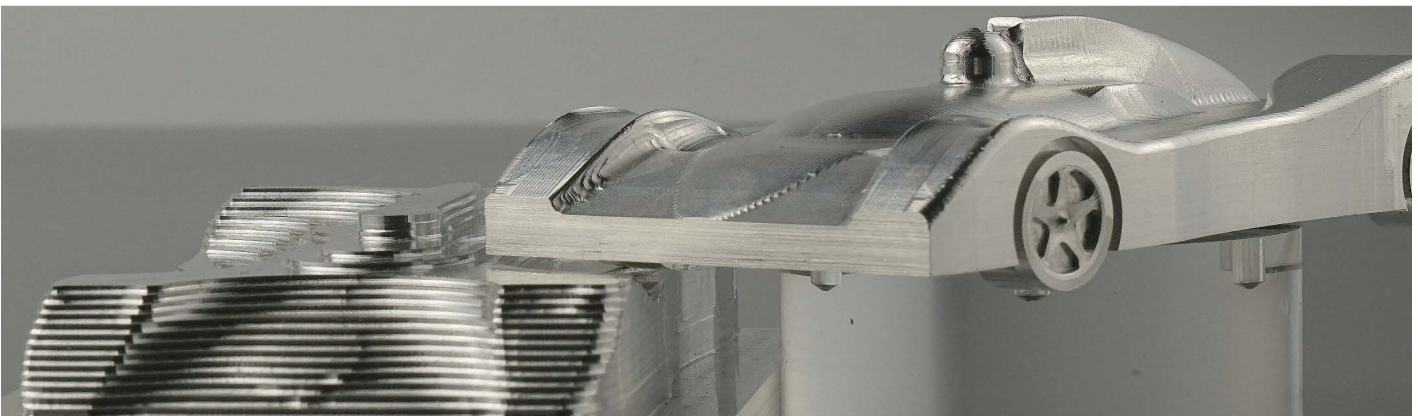

751 032

Hochleistungsfräser VHM 3 Schneiden ungleiche Teilung Carbide High Performance End Mills 3 Flutes Unequal Helix



- Schruppen und Schlichten
- Langspanende Werkstoffe, NE-Metalle
- 45° Spirale, ungleiche Stirnteilung
- Schutzfase an den Schneidecken
- Oberfläche poliert

- Roughing and finishing operations
- Long chipping materials, NF-metals
- 45° helix with unequal spacing
- Protective chamfers on edges
- Polished finish

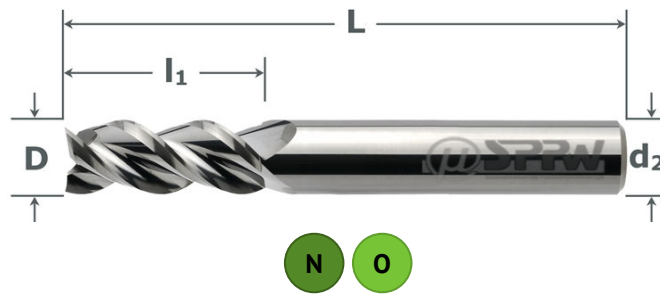

VHM	poliert
DIN 6527L	UT 45°
z:3	DIN 6535HA

ØD h10	Ød2 h6	L	l1	z	Art. No.	Stk/pce Euro	ØD h10	Ød2 h6	L	l1	z	Art. No.	Stk/pce Euro
3	6	57	10	3	7510320300	29,40	10	10	72	25	3	7510321000	51,50
4	6	57	13	3	7510320400	29,40	12	12	83	30	3	7510321200	69,90
5	6	57	15	3	7510320500	29,40	14	14	83	30	3	7510321400	108,40
6	6	57	18	3	7510320600	27,90	16	16	92	35	3	7510321600	147,00
7	8	63	20	3	7510320700	40,90	18	18	92	35	3	7510321800	176,40
8	8	63	20	3	7510320800	38,40	20	20	104	45	3	7510322000	207,60
9	10	72	22	3	7510320900	54,50							

757 032

Hochleistungsfräser VHM+Z.Cut ungleiche Teilung Carbide High Performance End Mills+Z.Cut Unequal Helix



- HPC-Schrupp- und Schlichtfräser
- Langspanende Werkstoffe, NE-Metalle
- Ungleiche Teilung und Schutzfasen
- Freistellung nach der Schneide
- Z.Cut-beschichtet für höhere Leistung

- HPC roughing, finishing operations
- Long chipping materials, NF-materials
- Unequal helix, protective chamfers
- Back clearance after cutting edge
- Z.Cut coating for higher performance

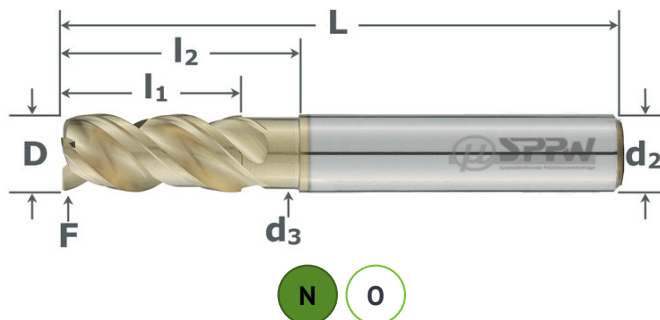

VHM	Z Cut
DIN 6527L	UT 45°
z:3	DIN 6535HA

ØD e8	Ød2 h5	L	l1	l2	z	F	Art. No.	Stk/pce Euro	ØD e8	Ød2 h5	L	l1	l2	z	F	Art. No.	Stk/pce Euro
6	6	57	13	21	3	0,2	7570320600	33,80	12	12	83	26	37	3	0,3	7570321200	86,80
8	8	63	19	26	3	0,2	7570320800	47,90	16	16	92	32	42	3	0,4	7570321600	128,10
10	10	72	22	30	3	0,25	7570321000	70,10	20	20	104	38	50	3	0,45	7570322000	177,60

— INFO —

TDC - Trochoidal Dynamic Cutting

Hochdynamisches Fräsen mit hohen Schnittgeschwindigkeiten und kontrollierten Eingriffstiefen.

CAM-optimierte Werkzeugwege + variable Zustellung + dynamische Vorschubgeschwindigkeiten
=> homogenen Spandicke und damit optimalen Schnittbedingungen bei der Fräsbearbeitung.

- Die volle Eingriffstiefe des Fräsers (3xØ) kann genutzt werden
- Die Schnittkräfte verteilen sich besser auf das Fräswerkzeug
- Es entsteht deutlich weniger Hitze im Fräsprozess
- Das Zeitspanvolumen erhöht sich drastisch
- Die Bearbeitungszeiten verringern sich deutlich
- Die Lebensdauer des Fräswerkzeugs wird erhöht

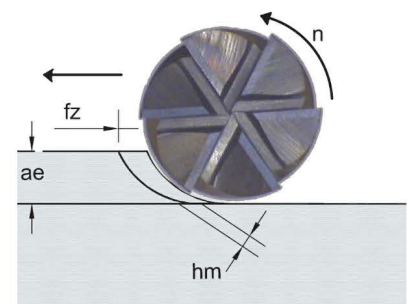



- Für Werkstoffe mit Klebeneigung
- TDC-/HPC-/3D-Fräsen im Formenbau
- Dünne Wandungen, tiefe Taschen
- Hohe Laufruhe, ungleiche Teilung
- Oberfläche poliert
- Long chipping materials, NF metals
- TDC/HPC/3D milling in toolmaking
- Deep pockets, small wall thickness
- Unequal helix allows smooth milling
- Polished finish

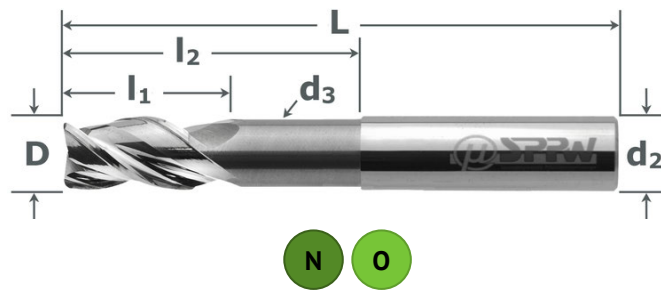

VHM	poliert
UT 37/40	z:3
DIN 6535HA	ER Torus

751150 - kurz | short version

ØD h9	Ød2 h6	L	l1	l2	z	r Radius	Ød3	Art. No.	Stk/pce Euro	ØD h9	Ød2 h6	L	l1	l2	z	r Radius	Ød3	Art. No.	Stk/pce Euro
4	4	50	6	22	3	0,2	3,6	7511500402	33,80	10	10	72	15	32	3	0,5	9,2	7511501005	75,60
4	4	50	6	22	3	0,5	3,6	7511500405	33,80	10	10	72	15	32	3	1	9,2	7511501010	75,60
5	5	50	7,5	22	3	0,2	4,5	7511500502	36,10	10	10	75	15	32	3	1,5	9,2	7511501015	75,60
5	5	50	7,5	22	3	0,5	4,5	7511500505	36,10	12	12	83	18	38	3	0,3	11	7511501203	95,60
6	6	57	9	21	3	0,3	5,5	7511500603	40,00	12	12	83	18	38	3	0,5	11	7511501205	95,60
6	6	57	9	21	3	0,5	5,5	7511500605	40,00	12	12	83	18	38	3	1	11	7511501210	95,60
6	6	57	9	21	3	1	5,5	7511500610	40,00	12	12	83	18	38	3	2	11	7511501220	95,60
6	6	57	9	21	3	1,5	5,5	7511500615	40,00	16	16	92	24	44	3	0,5	15	7511501605	135,50
8	8	63	12	27	3	0,3	7,4	7511500803	48,90	16	16	92	24	44	3	2	15	7511501620	135,50
8	8	63	12	27	3	0,5	7,4	7511500805	48,90	16	16	92	24	44	3	3	15	7511501630	135,50
8	8	63	12	27	3	1	7,4	7511500810	48,90	20	20	104	30	54	3	0,5	19	7511502005	218,40
8	8	63	12	27	3	1,5	7,4	7511500815	48,90	20	20	104	30	54	3	2	19	7511502020	218,40
10	10	72	15	32	3	0,3	9,2	7511501003	75,60	20	20	104	30	54	3	4	19	7511502040	218,40

751151 - lang | long version

ØD h9	Ød2 h6	L	l1	l2	z	r Radius	Ød3	Art. No.	Stk/pce Euro	ØD h9	Ød2 h6	L	l1	l2	z	r Radius	Ød3	Art. No.	Stk/pce Euro
6	6	80	9	44	3	0,3	5,5	7511510603	66,20	12	12	125	18	80	3	0,3	11	7511511203	129,20
6	6	80	9	44	3	1	5,5	7511510610	66,20	12	12	125	18	80	3	2	11	7511511220	129,20
8	8	100	12	64	3	0,3	7,4	7511510803	89,30	16	16	150	24	102	3	0,5	15	7511511605	214,20
8	8	100	12	64	3	1	7,4	7511510810	89,30	16	16	150	24	102	3	2	15	7511511620	214,20
10	10	125	15	85	3	0,3	9,2	7511511003	112,40	20	20	150	30	102	3	0,5	19	7511512005	360,20
10	10	125	15	85	3	1	9,2	7511511010	112,40	20	20	150	30	102	3	2	19	7511512020	360,20

— INFO —

TDC-/HPC- und 3D-Bearbeitung

- Herstellen tiefer Taschen mit geringsten Wandstärken
- Extrem scharfe Schneidkanten für leichten Schnitt
- Polierte Oberflächen für geringe Klebeneigung
- Ungleiche Teilung für extreme Laufruhe

TDC/HPC and 3D Milling

- Milling of slim walls and deep pockets
- Extremely sharp cuttind edges, easy milling
- Polished surfaces, no material build up
- Smooth milling due to unequal helix



751 653

Hochleistungs-Fräser VHM Mit Spanbrecher Carbide High Performance End Mills With Chip Breaker



- TDC, HPC in langspanenden Material
- Optimierte Kanten, große Spannuten
- Spanbrecher Typ WF
- Schutzfase an den Schneidecken
- Oberfläche poliert

- Trochoidal in long chipping materials
- Optimized edges, deep flutes
- Chip breaker type WF
- Protective chamfers on cutting edge
- Polished finish

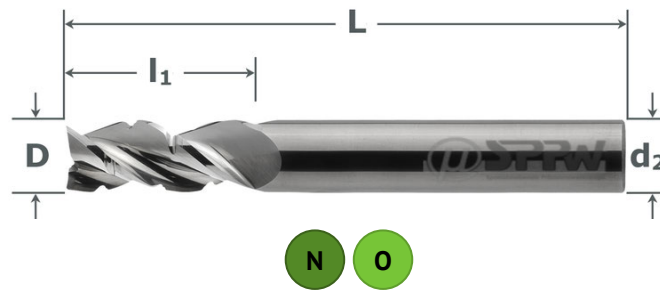

VHM	poliert
HPC-W 40°	z:3
DIN 6535HA	

ØD h10	Ød2 h6	L	l1	z	Art. No.	Stk/pce Euro	ØD h10	Ød2 h6	L	l1	z	Art. No.	Stk/pce Euro
10	10	72	22	3	7516531000	54,80	16	16	92	32	3	7516531600	149,00
12	12	83	26	3	7516531200	78,20	20	20	104	38	3	7516532000	215,40

751 683

Schrupfräser VHM Polierte Schneiden Carbide Roughing End Mills Polished Flutes



- Für langspanende Werkstoffe
- 35° Spirale mit großen Spanräumen
- Grobe Kordelverzahnung Typ WR
- Schutzfase an den Schneidecken
- Spannuten poliert
- Lieferzeit 3-5 Arbeitstage

- Roughing in long chipping material
- 35° helix with large flutes
- Roughing profile type WR
- Protective chamfers on edges
- Polished flutes
- Delivery time 3-5 work days

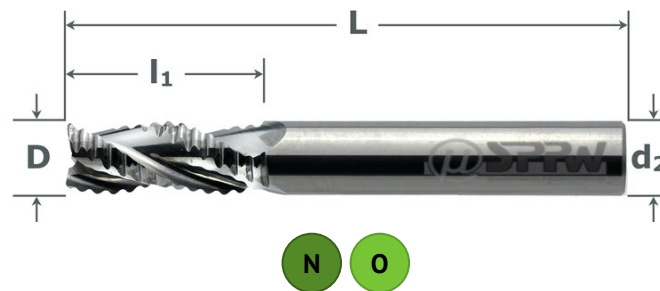

VHM	poliert
HPC WR	z:3
DIN 6535HA	

ØD h10	Ød2 h6	L	l1	z	Art. No.	Stk/pce Euro	ØD h10	Ød2 h6	L	l1	z	Art. No.	Stk/pce Euro
8	8	63	19	3	7516830800	44,20	16	16	92	32	3	7516831600	149,00
10	10	72	22	3	7516831000	54,80	20	20	104	38	3	7516832000	215,40
12	12	83	26	3	7516831200	78,20							

INFO

Die Fräserfamilie für langspanende Werkstoffe mit Klebeneigung

- 3 Schneiden mit tiefen Spannuten für hohen Spanabtrag
- Extrem scharfe Schneidkanten für leichten Schnitt
- Polierte Oberflächen für geringe Klebeneigung
- Verschiedene Varianten, z.B. mit Spanbrechern

The Milling Cutter Family for Performance in Aluminium

- 3 flutes with deep grooves, excellent chip removal
- Extremely sharp cutting edges, easy milling
- Polished surfaces, no material build-up
- Different versions, e.g. with chip breakers

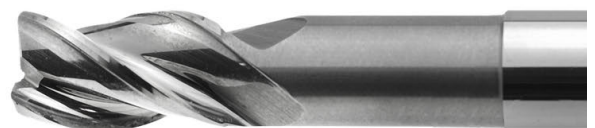

751 023

HSC-Schaftfräser VHM 2 Schneiden Carbide HSC End Mills 2 Flutes



- Leichtlegierungen und Kunststoffe
- Rechtsschneidend mit Rechtsspirale
- Zentrumschnitt zum Tauchen
- Extrem scharfe Schneidkanten
- Oberfläche poliert
- Light alloys and plastics
- Right hand helix, right hand cutting
- Center cutting for plunging
- Extremely sharp cutting edges
- Polished finish

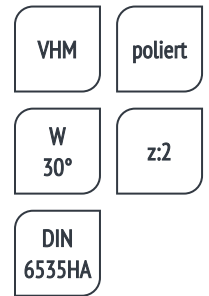
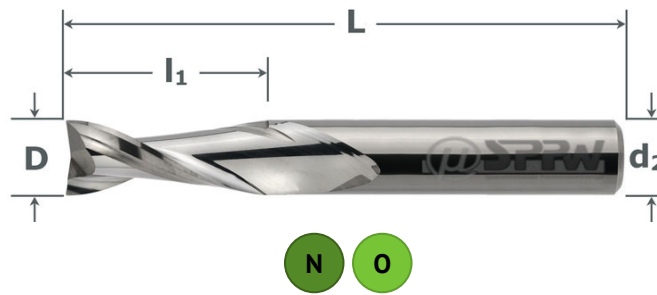

ØD h10	Ød2 h6	L	l1	z	Art. No.	Stk/pce Euro
2	3	50	8	2	7510230203	17,00
3	3	40	12	2	7510230300	14,70
4	4	40	14	2	7510230400	15,80
5	5	50	16	2	7510230500	18,10
6	6	50	18	2	7510230600	23,30

ØD h10	Ød2 h6	L	l1	z	Art. No.	Stk/pce Euro
8	8	63	20	2	7510230800	34,70
10	10	72	25	2	7510231000	46,60
12	12	83	30	2	7510231200	64,00
16	16	92	35	2	7510231600	135,90
20	20	104	45	2	7510232000	191,90

Schaft 6 h6 - shank 6 mm

ØD h10	Ød2 h6	L	l1	z	Art. No.	Stk/pce Euro
1	6	50	4	2	751023S010601	20,90
2	6	50	6	2	751023S020601	20,90
2	6	50	20	2	751023S020602	23,30
3	6	50	11	2	751023S030601	20,90
3	6	50	22	2	751023S030602	23,90

ØD h10	Ød2 h6	L	l1	z	Art. No.	Stk/pce Euro
4	6	50	14	2	751023S040601	24,90
4	6	50	22	2	751023S040602	25,90
5	6	50	22	2	751023S050601	25,90
6	6	50	22	2	751023S060601	25,90
8	6	58	20	2	751023S080601	46,10

751 020

HSC-Schaftfräser VHM Überlang Carbide HSC End Mills Extra Long



- Leichtlegierungen und Kunststoffe
- Rechtsschneidend mit Rechtsspirale
- Zentrumschnitt zum Tauchen
- Extrem scharfe Schneidkanten
- Oberfläche poliert
- Light alloys and plastics
- Right hand helix, right hand cutting
- Center cutting for plunging
- Extremely sharp cutting edges
- Polished finish

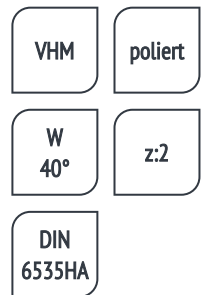
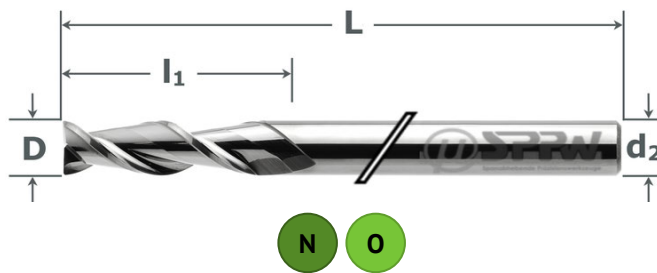

ØD h10	Ød2 h6	L	l1	z	Art. No.	Stk/pce Euro
6	6	100	21	2	7510200610	50,90
8	8	100	28	2	7510200810	74,30
8	8	160	28	2	7510200816	93,40
10	10	100	35	2	7510201010	87,80
10	10	160	35	2	7510201016	123,80

ØD h10	Ød2 h6	L	l1	z	Art. No.	Stk/pce Euro
12	12	100	42	2	7510201210	105,80
12	12	160	42	2	7510201216	149,60
16	16	100	48	2	7510201610	185,60
16	16	160	56	2	7510201616	235,10

751 000

HSC-Konturfräser VHM 2 Schneiden Geradegenutet
Carbide HSC Contouring End Mills 2 Straight Flutes



- Leichtlegierungen, Kunststoffe
- Blech, Platten, dünnwandiges Material
- Gerade genutet mit Zentrumschnitt
- Keine Zugkräfte am Werkstück
- Oberfläche poliert
- Light alloy, plastic, thin materials
- Straight flutes center cutting
- No drag or push on the workpiece
- Polished finish

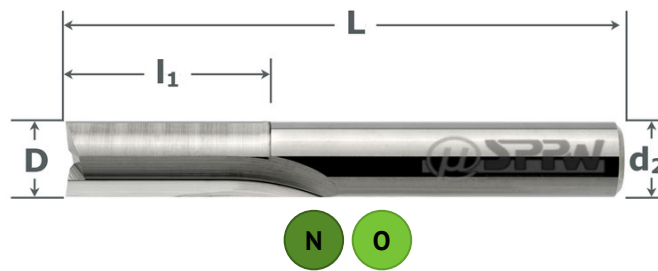

VHM	poliert
W 0°	z:2
DIN 6535HA	

ØD h10	Ød2 h6	L	l1	z	Art. No.	Stk/pce Euro	ØD h10	Ød2 h6	L	l1	z	Art. No.	Stk/pce Euro
3	3	40	12	2	7510000300	14,70	10	10	72	25	2	7510001000	46,60
4	4	40	14	2	7510000400	15,80	12	12	83	30	2	7510001200	64,00
5	5	50	16	2	7510000500	18,10	16	16	92	35	2	7510001600	135,90
6	6	50	18	2	7510000600	23,30	20	20	104	45	2	7510002000	191,90
8	8	63	20	2	7510000800	34,70							

751 040

HSC-Schaftfräser VHM 2 Schneiden Linksdrall
Carbide HSC End Mills 2 Flutes Left Hand Helix



- Leichtlegierungen und Kunststoffe
- Rechtsschneidend mit Linksspirale
- Spanauswurf nach unten
- Extrem scharfe Schneidkanten
- Oberfläche poliert
- Light alloys and plastics
- Left hand helix, right hand cutting
- Extremely sharp cutting edges
- Down-Cut
- Polished finish

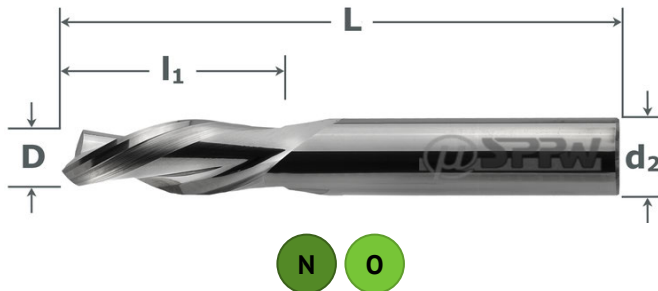

VHM	poliert
W 30°	z:2
DIN 6535HA	down cut

ØD h10	Ød2 h6	L	l1	z	Art. No.	Stk/pce Euro	ØD h10	Ød2 h6	L	l1	z	Art. No.	Stk/pce Euro
2	6	50	6	2	7510400206	23,00	8	8	63	20	2	7510400800	38,20
3	3	40	12	2	7510400300	15,00	10	10	72	25	2	7510401000	47,50
3	6	50	12	2	7510400306	25,10	12	12	83	30	2	7510401200	65,10
4	4	40	14	2	7510400400	16,10	16	16	92	35	2	7510401600	138,20
5	5	50	16	2	7510400500	18,40	20	20	104	45	2	7510402000	195,30
6	6	50	18	2	7510400600	23,70							



- Faserkunststoff, NE-Metall, Laminat
- Gegenläufigen Spannuten
- Simultan ziehend, schiebender Schnitt
- Gratfreie Kanten, keine Delamination
- Extrem scharfe Schneiden
- Oberfläche poliert

- FRP, NF-alloy, laminate
- Opposed helix
- Simultaneous dragging, compacting
- Burr free edges, no delamination
- Extremely sharp cutting edges
- Polished finish

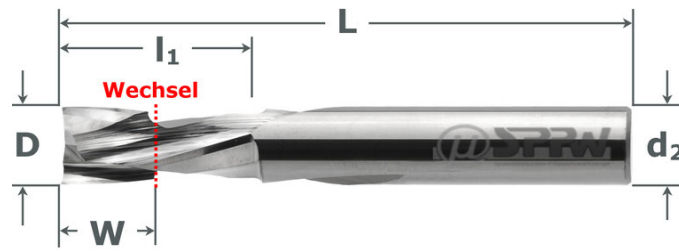

VHM	poliert
W +30 -30	z:2
DIN 6535HA	Butter Fly

ØD h10	Ød2 h6	L	l1	z	W	Art. No.	Stk/pce Euro	ØD h10	Ød2 h6	L	l1	z	W	Art. No.	Stk/pce Euro
2	6	40	6	2	3	7510270200	39,60	6	6	50	18	2	5	7510270600	38,60
3	3	40	12	2	3	7510270300	38,20	8	8	63	20	2	7	7510270800	46,50
3	6	50	12	2	3	7510270306	39,60	10	10	72	25	2	10	7510271000	61,20
4	4	40	14	2	4	7510270400	37,50	12	12	83	30	2	11	7510271200	80,00
5	5	50	16	2	7	7510270500	38,20								

INFO

Butter-Fly HSC-Fräser mit gegenläufigen Spannuten

Durch den Wechsel der Spiralrichtung erzeugt der Fräser an der Oberseite einen Druck nach unten zur Mitte des Werkstücks und gleichzeitig an der Unterseite einen Gegendruck nach oben. In Verbindung mit den extrem scharfen Schneiden entsteht eine sehr saubere, gratfreie Oberfläche.

Butter-Fly Milling Cutters

The direction of the helix on this cutter changes. It generates downward pressure to the center of the workpiece and simultaneously generates upward counterpressure on the bottom side. In conjunction with the extremely sharp cutting edges, a very clean, burr-free surface can be obtained.

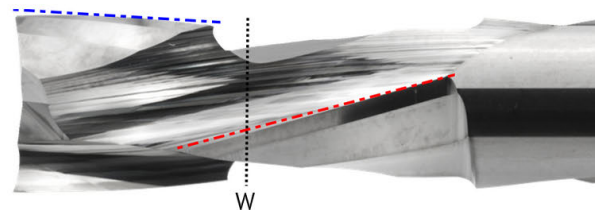

751 030

Hochleistungsfräser VHM Ungleiche Teilung Carbide High Performance End Mills Unequal Helix



- HPC-Schrupp- und Schlichtfräser
- Langspanende Werkstoffe
- 30° Spirale, ungleicher Stirnteilung
- Schutzfase an den Schneidecken
- Oberfläche poliert
- HPC roughing, finishing operations
- Long chipping materials, NF-metals
- 30° helix with unequal spacing
- Protective chamfer on cutting edges
- Polished finish

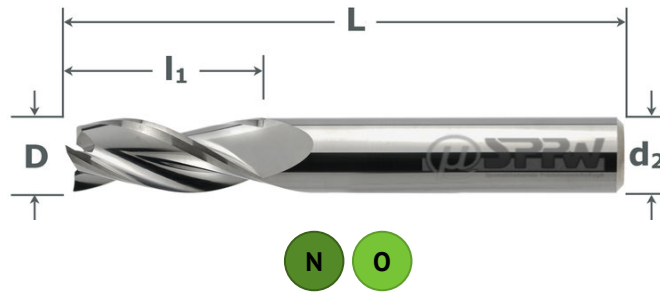

VHM	poliert
UT 30°	z:3
DIN 6535HA	

ØD h10	Ød2 h6	L	l1	z	Art. No.	Stk/pce Euro	ØD h10	Ød2 h6	L	l1	z	Art. No.	Stk/pce Euro
3	6	57	10	3	7510300300	28,00	10	10	72	25	3	7510301000	49,00
4	6	57	13	3	7510300400	28,00	12	12	83	30	3	7510301200	67,20
5	6	57	15	3	7510300500	28,00	14	14	83	30	3	7510301400	104,90
6	6	57	18	3	7510300600	26,60	16	16	92	35	3	7510301600	142,60
7	8	63	20	3	7510300700	39,50	18	18	92	35	3	7510301800	172,10
8	8	63	20	3	7510300800	36,50	20	20	104	45	3	7510302000	201,60
9	10	72	22	3	7510300900	51,80							

751 010

HSC-Konturfräser VHM 3 Schneiden Geradegenutet Carbide HSC Contouring End Mills 3 Straight Flutes



- Leichtlegierungen, Kunststoffe
- Blech, Platten, dünnwandiges Material
- Gerade genutet mit Zentrumschnitt
- Keine Zugkräfte am Werkstück
- Mit 3 Schneiden, höhere Laufruhe
- Oberfläche poliert
- Light alloys, plastics, thin materials
- Straight flutes center cutting
- No drag or push on the workpiece
- With 3 flutes, smooth milling
- Polished finish

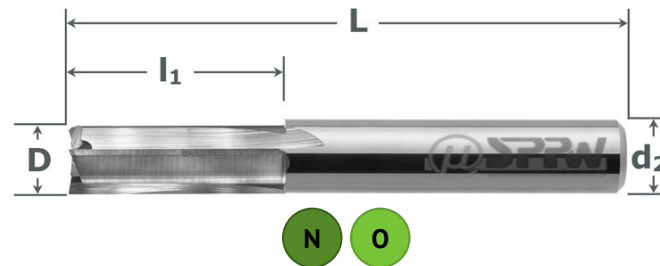

VHM	poliert
W 0°	z:3
DIN 6535HA	

ØD h10	Ød2 h6	L	l1	z	Art. No.	Stk/pce Euro	ØD h10	Ød2 h6	L	l1	z	Art. No.	Stk/pce Euro
3	3	40	12	3	7510100300	16,20	10	10	72	25	3	7510101000	49,00
4	4	40	14	3	7510100400	17,40	12	12	83	30	3	7510101200	67,20
5	5	50	16	3	7510100500	20,00	16	16	92	35	3	7510101600	142,60
6	6	50	18	3	7510100600	25,20	20	20	104	45	3	7510102000	201,60
8	8	63	20	3	7510100800	36,50							

751 050**HSC-Schaftfräser VHM 3 Schneiden Linksdrall**
Carbide HSC End Mills 3 Flutes Left Hand Helix

- Leichtlegierungen und Kunststoffe
- Rechtsschneidend mit Linksspirale
- Spanauswurf nach unten
- Extrem scharfe Schneidkanten
- Oberfläche poliert

- Light alloys and plastics
- Left hand helix, right hand cutting
- Extremely sharp cutting edges
- Down-Cut, chip removal to bottom
- Polished finish

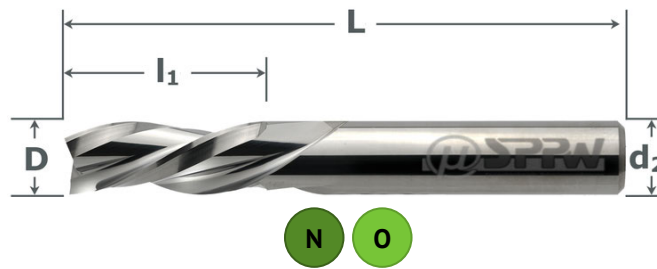

VHM	poliert
W 30°	z:3
DIN 6535HA	down cut

ØD h10	Ød2 h6	L	l1	z	Art. No.	Stk/pce Euro	ØD h10	Ød2 h6	L	l1	z	Art. No.	Stk/pce Euro
3	3	40	12	3	7510500300	16,50	10	10	72	25	3	7510501000	49,90
4	4	40	14	3	7510500400	17,70	12	12	83	30	3	7510501200	68,40
5	5	50	16	3	7510500500	20,30	16	16	92	35	3	7510501600	145,10
6	6	50	18	3	7510500600	25,60	20	20	104	45	3	7510502000	205,10
8	8	63	20	3	7510500800	37,10							

751 031**HSC-Schaftfräser VHM Schaumstoff**
Carbide HSC End Mills Foams

- Schaumstoffe, besonders PE und PUR
- Rechtsschneidend mit Rechtsspirale
- Steile Spirale für gute Spanabfuhr
- Saubere Oberflächen bei Taschen
- Freistellung und Schutzfase
- Oberfläche poliert

- Foams, especially PE and PUR
- Right hand helix, right hand cutting
- Steep helix for good chip removal
- Smooth surfaces on slots, pockets
- Back clearance and protective chamfer
- Polished finish

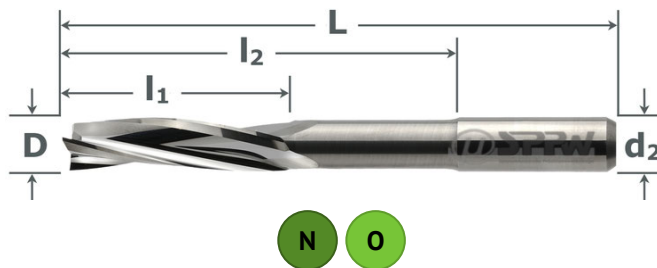

VHM	poliert
W 20°	z:3
DIN 6535HA	

ØD h10	Ød2 h6	L	l1	l2	z	Art. No.	Stk/pce Euro	ØD h10	Ød2 h6	L	l1	l2	z	Art. No.	Stk/pce Euro
3	3	75	20	40	3	7510310300	37,80	8	8	150	40	115	3	7510310803	90,70
4	4	75	30	45	3	7510310401	51,70	10	10	100	40	70	3	7510311001	107,10
5	5	75	25	45	3	7510310500	51,70	10	10	120	50	85	3	7510311002	119,70
6	6	75	25	45	3	7510310601	58,00	10	10	150	50	115	3	7510311003	133,60
6	6	100	40	70	3	7510310602	71,80	12	12	125	50	85	3	7510311201	177,70
8	8	100	40	70	3	7510310801	84,40	12	12	150	50	115	3	7510311202	184,00

INFO**Polierte Spannut**

Rapid-Line HSC-Fräser haben einen deutlich verbesserten Spanabfluss. Es treten geringere Bearbeitungstemperaturen auf, Überhitzung und Aufschweißungen werden vermieden. Rapid-Line Fräser haben eine deutlich längere Lebensdauer und es können zudem bessere Oberflächen erzielt werden.

Polished Flutes

Rapid-Line HSC cutters have significantly improved chip flow. Lower machining temperatures occur, overheating and welding are avoided. Rapid-Line milling cutters have a significantly longer tool life. Better surfaces can be achieved.

751 034

Planfräser mit HM-Kopf 3 Schneiden Carbide Surface Milling Cutter 3 Flutes



- Planfräsen größerer Oberflächen
- Langspanende Werkstoffe, NE-Metalle
- 30° Spirale mit Eckenradius 0,5 mm
- Stahlschaft mit gelötetem HM-Kopf
- Surface milling of larger areas
- Long chipping materials, NF-metals
- 30° helix with corner radius 0,5 mm
- Steel shank with brazed carbide head

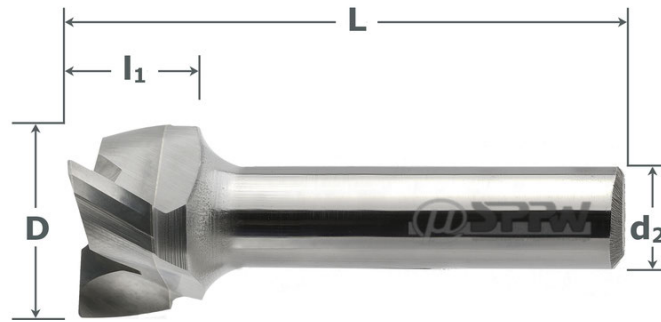

VHM	poliert
W 30°	z:3
DIN 6535HA	



ØD h10	Ød2 h8	L	l1	z	Art. No.	Stk/pce Euro
10	6	50	8	3	7510341000	37,40
12	6	50	8	3	7510341200	50,30
14	10	50	8	3	7510341400	63,20
16	10	50	8	3	7510341600	76,10

ØD h10	Ød2 h8	L	l1	z	Art. No.	Stk/pce Euro
18	10	50	8	3	7510341800	89,00
20	10	50	8	3	7510342000	101,90
30	12	50	8	3	7510343000	114,80

751 035

HSC-Radiusfräser VHM 3 Schneiden Carbide HSC Radius End Mills 3 Flutes



- HSC-Schrupp-/Schlichtfräser
- Langspanende Werkstoffe
- 30° Spirale, ungleiche Stirnteilung
- Oberfläche poliert
- Lieferzeit 5 - 8 Arbeitstage
- HSC roughing, finishing operations
- Long chipping materials, NF-metals
- 30° helix with unequal spacing
- Polished finish
- Delivery time 5 - 8 working days

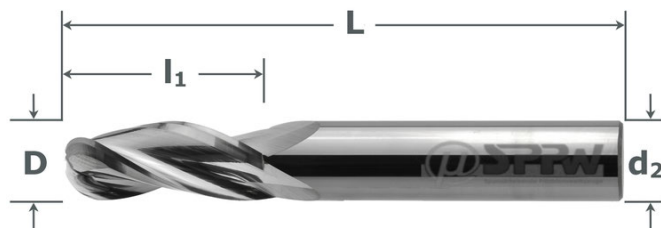

VHM	poliert
W 30°	z:3
DIN 6535HA	
Radius	



ØD h10	Ød2 h6	L	l1	z	Art. No.	Stk/pce Euro
3	6	57	10	3	7510350300	37,10
4	6	57	13	3	7510350400	37,10
5	6	57	15	3	7510350500	37,10
6	6	57	18	3	7510350600	35,10
7	8	63	20	3	7510350700	52,20
8	8	63	20	3	7510350800	44,60
9	10	72	22	3	7510350900	63,30

ØD h10	Ød2 h6	L	l1	z	Art. No.	Stk/pce Euro
10	10	72	25	3	7510351000	59,90
12	12	83	30	3	7510351200	82,00
14	14	83	30	3	7510351400	122,80
16	16	92	35	3	7510351600	166,90
18	18	92	35	3	7510351800	201,40
20	20	104	45	3	7510352000	235,80

751 190

HSC-Schaftfräser VHM für Fasergewebe 2 Schneiden Carbide Cross Cut HSC Router End Mills Aramid 2 Flutes



- Fasergewebewerkstoffe (Aramid)
- Gegenläufige Verzahnung
- Rechtsschneidend, Rechts-/Linksspirale
- Extrem scharfe Schneidkanten
- Keine Delamination bei Textilien
- Oberfläche poliert

- Woven fiber materials (Aramids)
- Up- and down-cut, right hand cutting
- Extremely sharp cutting edges
- No delamination in textile structure
- Polished finish

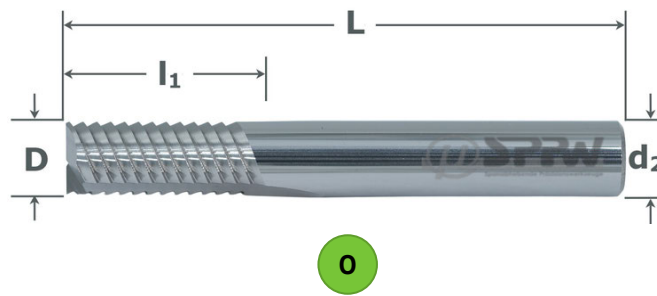

VHM	poliert
AFRP 0°	z:2 1+1
DIN 6535HA	

ØD h10	Ød2 h6	L	l1	Art. No.	Stk/pce Euro	ØD h10	Ød2 h6	L	l1	Art. No.	Stk/pce Euro
5	5	50	15	7511900500	65,10	8	8	63	18	7511900800	87,20
5	5	75	20	7511900500L	73,50	8	8	80	30	7511900800L	101,90
6	6	57	18	7511900600	67,20	10	10	72	20	7511901000	112,40
6	6	75	25	7511900600L	78,80	10	10	80	35	7511901000L	129,20

751 194

HSC-Schaftfräser VHM für Fasergewebe 4 Schneiden Carbide Cross Cut HSC Router End Mills Aramid 4 Flutes



- Fasergewebewerkstoffe (Aramid)
- Gegenläufige Verzahnung
- Rechtsschneidend, Rechts-/Linksspirale
- Extrem scharfe Schneidkanten
- Keine Delamination bei Textilien
- Oberfläche poliert

- Woven fiber materials (Aramids)
- Up- and down-cut, right hand cutting
- Extremely sharp cutting edges
- No delamination in textile structure
- Polished finish

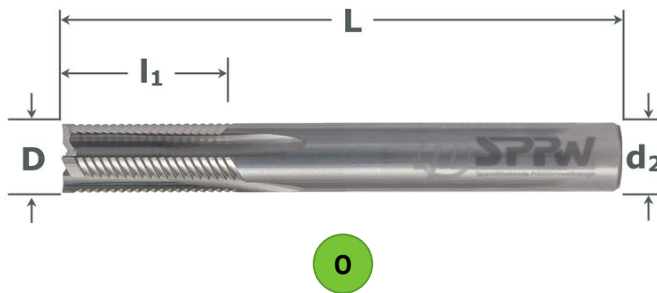

VHM	poliert
AFRP 0°	z:4 2+2
DIN 6535HA	

ØD h10	Ød2 h6	L	l1	z	Art. No.	Stk/pce Euro	ØD h10	Ød2 h6	L	l1	z	Art. No.	Stk/pce Euro
6	6	60	20	4	7511940600	57,60	10	10	72	32	4	7511941000	109,70
6	6	75	35	4	7511940601	91,20	10	10	100	50	4	7511941001	168,10
8	8	75	32	4	7511940800	70,10	12	12	83	32	4	7511941200	135,90
8	8	100	40	4	7511940801	112,20	12	12	120	55	4	7511941201	191,30

— INFO —



Gegenläufige Schneiden

Die gegenläufige Anordnung der Schneiden – up-cut und down-cut – erzeugt bei der Bearbeitung während einer Umdrehung Schnittkräfte in gegenüberliegende Richtungen. Die Schnittkräfte neutralisieren sich wechselseitig und schaffen so ein kräfteutrales Werkzeug.

Opposed Cutting Edges

The opposed cutting edge alignment - up-cut and down-cut - generates cutting forces in opposite directions while machining. The cutting forces are neutralized, thus creating a force-neutral tool.

751 902

CNC Faskant-Umfangsfräser VHM 90°
Carbide V-Groove Milling Cutters 90°



- V-Nutfräsen und Umfangsfräsen
- Aluminium-Verbundplatten
- Mit Kunststoffkern
- Einsatz auf CNC-Maschinen
- Oberfläche blank
- V-slotting and circumference milling
- Aluminum-composite-sheets
- With plastic core
- Version for CNC applications
- Bright finish

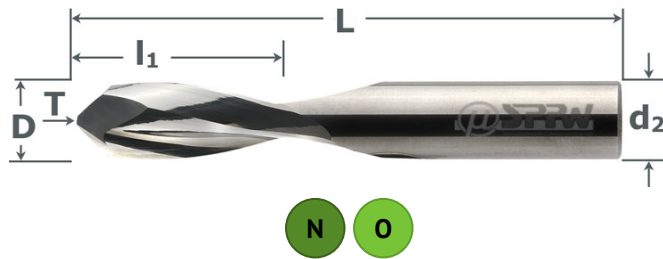

VHM	poliert
W 20°	90°
z:2	DIN 6535HA

ØD	Ød2	L	l1	z	T	Art. No.	Stk/pce Euro	ØD	Ød2	L	l1	z	T	Art. No.	Stk/pce Euro
4	4	50	10	2	0,4	7519020400	22,30	8	8	58	20	2	0,8	7519020800	47,50
6	6	54	16	2	0,6	7519020600	30,60	10	10	66	24	2	1	7519021000	63,50

751 900

Faskantfräser VHM 90° oder 135°
Carbide Creasing Cutters 90° or 135°



- V-Nutfräsen zum späteren Kanten
- Aluminium-Verbundplatten
- Mit Kunststoffkern
- Kantwinkel 90° und 135°
- Oberfläche blank
- V-slotting for following folding
- Aluminum-plastic-sheets
- With plastic core
- Folding angles 90° and 135°
- Bright finish

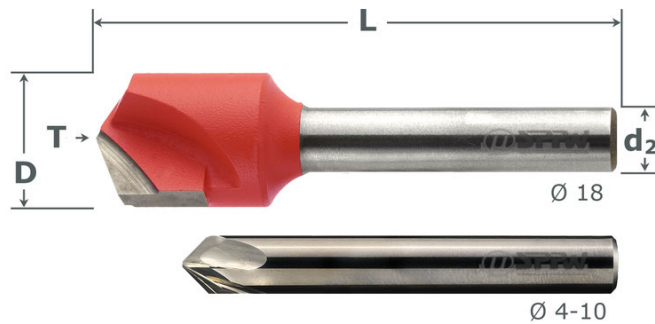

VHM	poliert
W 0°	90°
z: 2-4	DIN 6535HA

ØD	Ød2	L	a	z	T	Art. No.	Stk/pce Euro	ØD	Ød2	L	a	z	T	Art. No.	Stk/pce Euro
4	4	50	90°	2	0,4	7519000400	18,00	10	10	66	90°	4	1	7519001000	48,70
6	6	54	90°	2	0,6	7519000600	22,40	18	8	59	135°	2	2	7519001820	75,50
8	8	58	90°	4	0,8	7519000800	39,40	18	8	59	90°	2	3	7519001830	75,50

— INFO —

Aluminium-Verbundplatten

Zuerst wird eine V-förmige Falz in die innenliegende Seite der Verbundplatte gefräst. Dabei sollte eine dünne Schicht des Kernmaterials stehen bleiben, um die Deckplatten zu schützen. Die verbleibende Deckplatte kann jetzt in die gewünschte Form gekantet werden. Das Kanten kann per Hand erfolgen. Es entsteht eine saubere Biegekante.

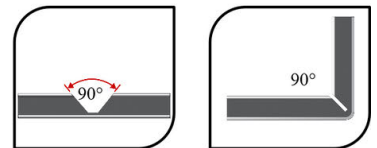

ACM - Aluminum Composite Materials

A V-shaped groove is milled into the opposite side of the ACM. A small layer of the plastic filling should remain to protect the cover sheet. The remaining outer cover sheet can now be bent to get the desired form. Folding can be done manually and will result in a clean folding line.

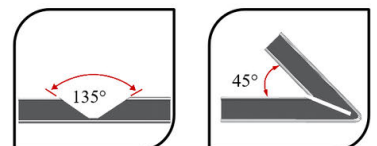

751 077

HSC-Schaftfräser VHM Waben-Verbundwerkstoffe
Carbide HSC End Mills Honeycomb



- Waben-Verbundwerkstoffe
- Extra Verzahnung, ziehender Schnitt
- Gute Oberfläche für die Weiterarbeit
- Extrem scharfe Schneidkanten
- Multiflute-Stirnverzahnung
- Ab Ø 14 mit HSS-Schaft

- Honeycomb materials
- Special flute geometry, dragging cut
- Good surfaces for further processing
- Extremely sharp cutting edges
- Multiflute point, straight shank
- From Ø 14 with HSS shank

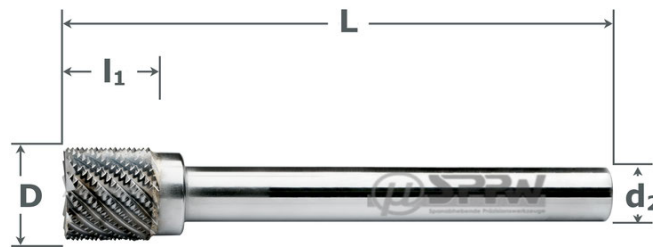

VHM	poliert
W 50°	z: multi
DIN 6535HA	Honey Comb

ØD h10	Ød2 h6	L	l1	Art. No.	Stk/pce Euro	ØD h10	Ød2 h6	L	l1	Art. No.	Stk/pce Euro
6	6	50	16	7510770600	35,10	16	12	100	17	7510771600	160,90
8	8	63	19	7510770800	53,10	20	12	100	17	7510772000	214,50
10	10	72	22	7510771000	73,20	24	12	100	10	7510772400	237,20
12	12	83	26	7510771200	102,30	24	12	100	17	7510772401	268,20
14	12	100	17	7510771400	101,90	44*	12	100	17	7510774400	504,10

751 078

Modulare Systemfräser VHM Honeycomb mit Schneidmesser
Modular Milling Cutters for Honeycomb with Circular Cutter



- Modularer Systemfräser
- Satz: Schaft, Fräser und Schneidmesser
- Verschiedene Konfigurationen
- Speziell für Waben-Verbundwerkstoffe
- Extrem scharfe Schneidkanten

- Modular milling system as set
- Set: arbor, hogger and blade
- Different configurations
- Honeycomb materials
- Good surfaces for further processing
- Extremely sharp cutting edges

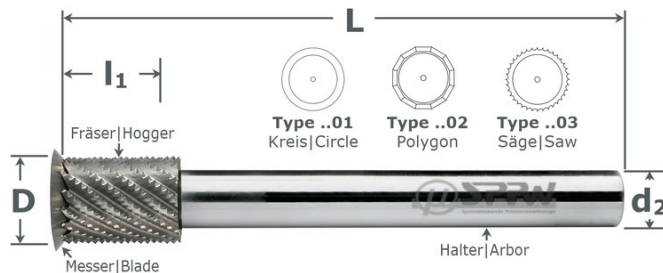

VHM	poliert
Set modulR	z: multi
DIN 6535HA	Honey Comb

ØD e9	Ød2 h6	L	l1	DE	EN	Art. No.	Stk/pce Euro
12	12	83	26	Kreis	Circle	7510781201	313,10
12	12	83	26	Polygon	Polygon	7510781202	344,60
12	12	83	26	Säge	Saw	7510781203	344,60
20	12	100	20	Kreis	Circle	7510782001	423,80
20	12	100	20	Polygon	Polygon	7510782002	471,10
20	12	100	20	Säge	Saw	7510782003	471,10
24	12	100	17	Kreis	Circle	7510782401	477,60
24	12	100	17	Polygon	Polygon	7510782402	529,40
24	12	100	17	Säge	Saw	7510782403	529,40
44	12	100	17	Kreis	Circle	7510784401	697,30
44	12	100	17	Polygon	Polygon	7510784402	767,10
44	12	100	17	Säge	Saw	7510784403	767,10

751 079

Modulare Systemfräser VHM Honeycomb - Einzelteile

Modular Milling Cutters for Honeycomb - Spare Parts



- Modularer Systemfräser 751078
- Einzelne Bestandteile
- Kreismesser, Fräser und Halter
- Befestigung mittels Schraube M4
- Extrem scharfe Schneidkanten
- Modular milling system 751078
- Spare and extra parts
- Arbor, hogger and blade
- Assembly with screw M4
- Extremely sharp cutting edges

Teile
partsHoney
Comb

751078 Einzelteile | spare parts

Größe size	Teil part	ØDxH	L	Art. No.	Stk/pce Euro
12	Fräskopf	12x26		7510781226	119,20
12	Halter	12x23	80	7510781278	123,80
12	Kreis	13x3-90°		7510781301	115,80
12	Polygon	13x3-90°		7510781302	160,90
12	Säge	13x3-90°		7510781303	160,90
20	Fräskopf	20x20		7510782020	236,00
20	Halter	12x17	97	7510782089	123,80
20	Kreis	21x3-120°		7510782101	138,40
20	Polygon	21x3-120°		7510782102	205,90
20	Säge	21x3-120°		7510782103	205,90
24	Fräskopf	24x17		7510782417	282,80
24+44	Halter	12x14	97	7510782444	136,10
24	Kreis	25x3-120°		7510782501	138,40
24	Polygon	25x3-120°		7510782502	212,40
24	Säge	25x3-120°		7510782503	212,40
44	Fräskopf	44x17		7510784417	504,70
44	Kreis	47x3-120°		7510784701	164,10
44	Polygon	47x3-120°		7510784702	263,80
44	Säge	47x3-120°		7510784703	263,80



790 070 HC

HSC-Kompressionsfräser VHM+Dia.HC Carbide HSC Up and Down Cutter+Dia.HC



- Faserkunststoffe
- Gegenläufige Nuten, Up&Down-Cut
- Spiralwechsel, Schnittkräfte mittig
- Simultan ziehend, schiebend
- Oberfläche Dia.HC
- Diamant.Plus (12µm) auf Anfrage
- Fiber reinforced plastics
- Opposed helix, up & down cut
- Helix changes direction, right to left
- Simultaneous up down cut
- With Dia.HC coating
- Diamond.Plus coating on request

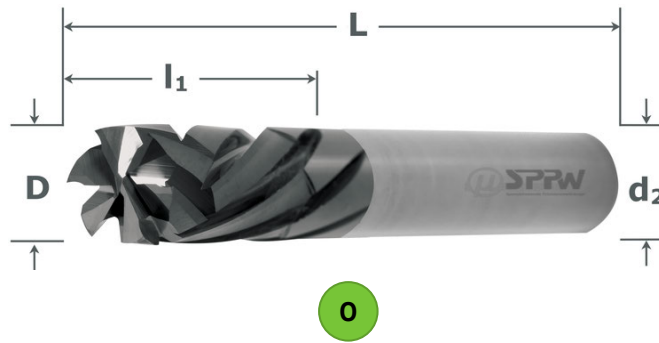

VHM	Dia HC
W +20 -20	DIN 6535HA
CFK carbone	

ØD h10	Ød2 h6	L	l1	l2	Art. No.	Stk/pce Euro	ØD h10	Ød2 h6	L	l1	l2	Art. No.	Stk/pce Euro
6	6	75	15	7,5	7900700600HC	89,90	10	10	100	25	12,5	7900701000HC	138,10
8	8	75	20	10	7900700800HC	118,50	12	12	100	30	15	7900701200HC	173,60

790 067 HC

HSC-Schaftfräser VHM+Dia.HC - CFK gerade Carbide HSC End Mills+Dia.HC - CFRP



- Carbonfaser-Verbundwerkstoff
- Optimierte Geometrie, Spanbreche
- Fortlaufender Schnitt
- Gerade Nuten, keine Zugkraft
- Oberfläche Dia.HC beschichte
- Diamant.Plus (12µm) auf Anfrag
- Carbone fiber reinforced materia
- Optimized geometry, chip breaker
- Continued cut, good chip remova
- Straight flutes, no dra
- With Dia.HC coatin
- Diamond.Plus coating on reques

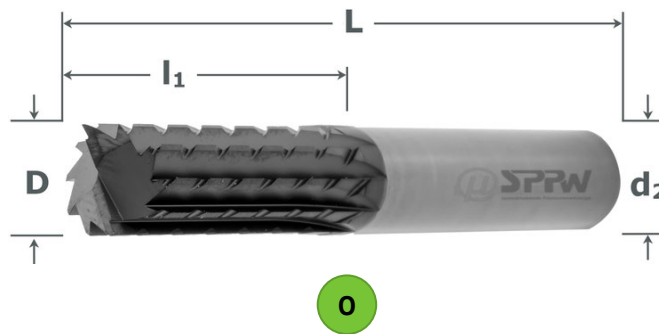

VHM	Dia HC
WX 0°	Multi
DIN 6535HA	CFK carbone

ØD e9	Ød2 h6	L	l2	Art. No.	Stk/pce Euro	ØD e9	Ød2 h6	L	l2	Art. No.	Stk/pce Euro
4	6	80	16	7900670400HC	82,10	10	10	100	32	7900671000HC	127,80
6	6	80	20	7900670600HC	76,40	10	10	120	50	7900671001HC	173,00
6	6	100	35	7900670601HC	83,30	12	12	100	32	7900671200HC	166,10
8	8	100	32	7900670800HC	116,10	12	12	150	60	7900671201HC	217,40
8	8	120	40	7900670801HC	133,60						

790 069 HC

HSC-Schaftfräser VHM+Dia.HC - CFK Down-Cut Carbide HSC End Mills+Dia.HC - CFRP Down-Cut



- Carbonfaser-Verbundwerkstoffe
- optimierte Geometrie mit Spanbrecher
- Schiebender Schnitt - Down-Cut
- Oberfläche Dia.HC beschichtet
- Diamant.Plus (12µm) auf Anfrage
- Carbone fiber reinforced material
- Optimized Geometry with chip breaker
- Down-cut, chip removal to bottom
- With Dia.HC coating
- Diamond.Plus coating on request

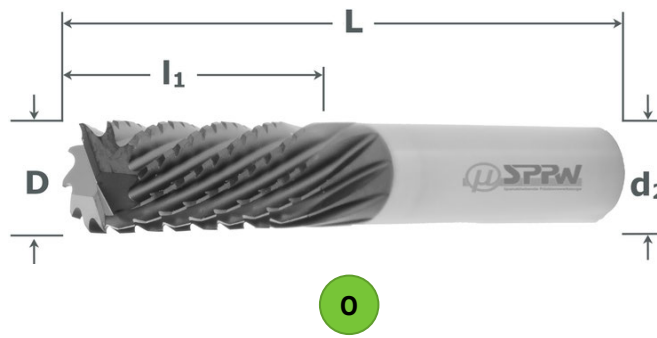

VHM	Dia HC
WX -30°	Multi
DIN 6535HA	CFK carbone

ØD e9	Ød2 h6	L	l2	Art. No.	Stk/pce Euro	ØD e9	Ød2 h6	L	l2	Art. No.	Stk/pce Euro
4	6	80	16	7900690400HC	76,80	10	10	100	32	7900691000HC	123,20
6	6	80	20	7900690600HC	72,40	10	10	120	50	7900691001HC	153,20
6	6	100	35	7900690601HC	77,70	12	12	100	32	7900691200HC	146,80
8	8	100	32	7900690800HC	97,90	12	12	150	60	7900691201HC	185,60
8	8	120	40	7900690801HC	137,50						

790

HSC-Kopierfräser VHM+Dia.HC - CFK Carbide HSC End Copyind Mills+Dia.HC - CFRP



- Carbonfaser-Verbundwerkstoffe
- Vollradius zum Kopierfräsen
- Optimierte Geometrie, Spanbrecher
- Fortlaufender Schnitt
- Oberfläche Dia.HC beschichtet
- Diamant.Plus (12µm) auf Anfrage
- Carbone fiber reinforced material
- With radius for copying operations
- Optimized Geometry, chip breakers
- Continued cut, good chip removal
- With Dia.HC coating
- Diamond.Plus coating on request

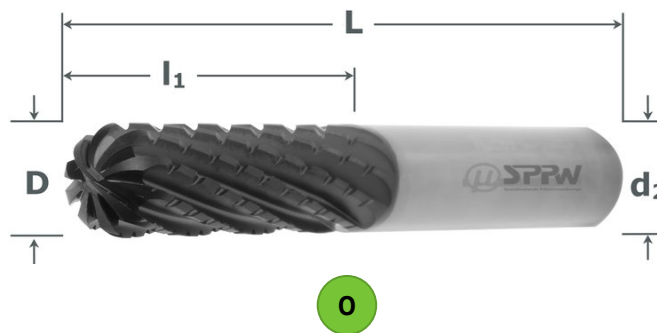

VHM	Dia HC
WX 30°	DIN 6535HA
CFK carbone	

ØD -0,02	Ød2 h6	L	l1	Art. No.	Stk/pce Euro	ØD -0,02	Ød2 h6	L	l1	Art. No.	Stk/pce Euro
4	4	60	19	7900650400HC	85,60	10	10	72	37	7900651000HC	127,00
6	6	60	23	7900650600HC	78,60	12	12	83	38	7900651200HC	163,60
8	8	75	36	7900650800HC	102,30						

— INFO —



Dia.Aero Diamantbeschichtung

Entwickelt, um höchste Oberflächenqualität bei der Zerspaltung von CFK zu erreichen. Optimale Schichthftung und einzigartigen Schichtglätte garantieren hohe Produktivität. Trotz einer Schichtdicke von bis zu 14 µm verändert sich die Mikrogeometrie des Fräasers nicht.

Dia.Aero Diamond Coating

Developed to provide the highest surface quality when machining CFRP. Optimal layer adhesion and unique layer smoothness guarantee high productivity. Despite a coating thickness of up to 14 µm the micro-geometry of the cutter does not change.

751 060 HC

HSC-Kompressionsfräser VHM+Dia.HC Carbide HSC Up and Down Cutter+Dia.HC



- Faserkunststoffe
- Gegenläufige Nuten mit Spanbrechern
- Spiralwechsel, Schnittkräfte mittig
- Simultan ziehend, schiebend
- Oberfläche Dia.HC beschichtet

- Fiber reinforced plastics
- Opposed helix with chip breaker
- Helix changes direction, right to left
- Dragging and compacting cut
- With Dia.HC coating

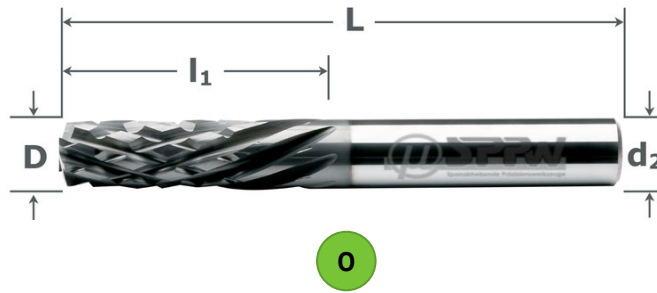

VHM	Dia HC
W +20 -20	Multi
DIN 6535HA	GFK CFK

ØD h10	Ød2 h6	L	l1	Wechsel	Art. No.	Stk/pce Euro
6	6	57	13	4	7510600604HC	81,25
6	6	57	13	6,5	7510600606HC	83,40
6	6	60	22	11	7510600611HC	90,95
8	8	63	19	6	7510600806HC	104,70
8	8	63	19	9,5	7510600809HC	107,95
8	8	78	32	16	7510600816HC	119,75

ØD h10	Ød2 h6	L	l1	Wechsel	Art. No.	Stk/pce Euro
10	10	72	22	7	7510601007HC	125,00
10	10	72	22	11	7510601011HC	128,25
10	10	78	35	17,5	7510601017HC	141,15
12	12	83	25	8	7510601208HC	191,30
12	12	83	26	13	7510601213HC	196,90
12	12	83	40	20	7510601220HC	210,85

791060 - Diamant.Plus | Diamond.Plus coating

ØD h10	Ød2 h6	L	l1	Wechsel	Art. No.	Stk/pce Euro
6	6	57	13	4	7910600604	113,80
6	6	57	13	6,5	7910600606	116,90
6	6	60	22	11	7910600611	125,10
8	8	63	19	6	7910600806	155,90
8	8	63	19	9,5	7910600809	160,20
8	8	78	32	16	7910600816	175,20

ØD h10	Ød2 h6	L	l1	Wechsel	Art. No.	Stk/pce Euro
10	10	72	22	7	7910601007	192,40
10	10	72	22	11	7910601011	197,80
10	10	78	35	17,5	7910601017	225,80
12	12	83	26	8	7910601208	293,20
12	12	83	25	13	7910601213	294,50
12	12	83	40	20	7910601220	333,10

— INFO —

Kompressionsfräsen

Der Kompressionsfräser löst typische Probleme, die bei der Bearbeitung von Faserkunststoffen auftreten:

- Delamination
- Oberflächengüte an den Schnittkanten
- Abtransport der Späne

Durch den Wechsel der Spiralrichtung erzeugt das Werkzeug an der Oberseite einen Druck nach unten zur Mitte des Werkstücks und gleichzeitig an der Unterseite einen Gegendruck nach oben zur Mitte des Werkstücks. Durch die Spanbrecher werden die Späne sauber gebrochen und schnell aus dem Prozess abgeführt, so dass sie nicht anhaften können.

Up and Down Compression Cutters

This milling cutter solves several of the problems that occur, when machining fibre reinforced plastics:

- Delamination
- Surface quality
- Chip control

The tool helix changes direction creating pressure from the top to the center and at the same time from the bottom to the center of the work piece, thus concentrating the axial effects in the middle of the workpiece. The chip breakers facilitate chip transport and remove chips rapidly from the cutting process.

Funktionsprinzip working principle

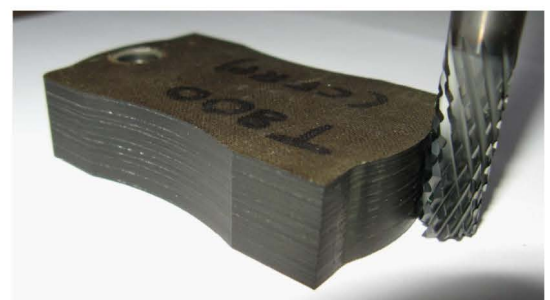
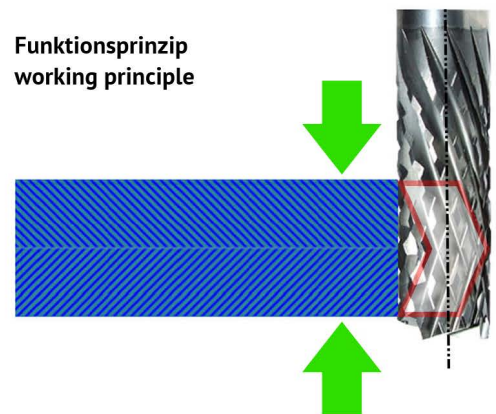

751 065

HSC-Schaftfräser VHM GFK / CFK 5 Schneiden Carbide HSC End Mills GFRP / CFRP 5 Flutes



- Faser-Verbundwerkstoffe
- Große Spannuten, gute Spanabfuhr
- Synchrone Spanbrecher
- Fortlaufender Schnitt
- Gerade Nuten, keine Zugkräfte
- Oberfläche poliert

- Fiber reinforced compound materials
- Big flutes, synchronized chip breakers
- Continued cut and good chip removal
- Straight flutes, no drag
- Polished finish

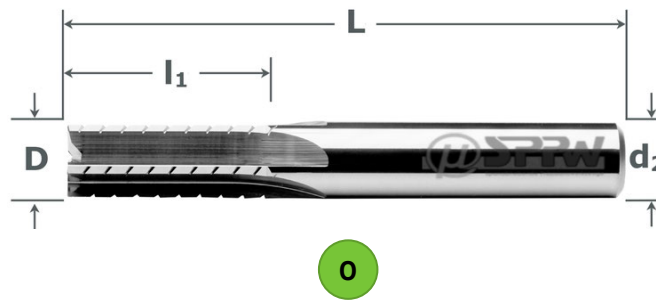

VHM	poliert
W 0°	z:5
DIN 6535HA	GFK CFK

ØD h10	Ød2 h6	L	l1	z	Art. No.	Stk/pce Euro	ØD h10	Ød2 h6	L	l1	z	Art. No.	Stk/pce Euro
2	6	57	7	5	7510650206	35,50	6	6	57	18	5	7510650600	33,80
3	6	57	12	5	7510650306	35,50	8	8	63	20	5	7510650800	51,10
4	6	57	14	5	7510650406	35,50	10	10	72	25	5	7510651000	73,20
5	6	57	16	5	7510650506	31,50	12	12	83	30	5	7510651200	102,30

751 065 HC

HSC-Schaftfräser VHM+Dia.HC GFK / CFK 5 Schneiden Carbide HSC End Mills+Dia.HC GFRP / CFRP 5 Flutes



- Faser-Verbundwerkstoffe
- Große Spannuten, gute Spanabfuhr
- Synchrone Spanbrecher
- Fortlaufender Schnitt
- Gerade Nuten, keine Zugkräfte
- Oberfläche Dia.HC beschichtet

- Fiber reinforced compound material
- Big flute, synchronized chip breakers
- Continued cut, good chip removal
- Straight flutes, no drag
- With Dia.HC coating

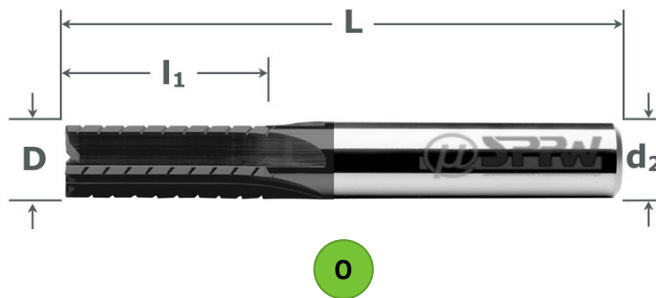

VHM	Dia HC
W 0°	z:5
DIN 6535HA	GFK CFK

ØD h10	Ød2 h6	L	l1	z	Art. No.	Stk/pce Euro	ØD h10	Ød2 h6	L	l1	z	Art. No.	Stk/pce Euro
2	6	57	7	5	7510650206HC	43,60	6	6	57	18	5	7510650600HC	42,60
3	6	57	12	5	7510650306HC	43,60	8	8	63	20	5	7510650800HC	61,50
4	6	57	14	5	7510650406HC	43,60	10	10	72	25	5	7510651000HC	82,50
5	6	57	16	5	7510650506HC	39,60	12	12	83	30	5	7510651200HC	115,30

751 066

HSC-Schaftfräser VHM GFK / CFK 6 Schneiden Carbide HSC End Mills GFRP / CFRP 6 Flutes



- Faser-Verbundwerkstoffe
- Große Spannuten, gute Spanabfuhr
- Synchrone Spanbrecher
- Fortlaufender Schnitt
- Oberfläche poliert
- Fiber reinforced compound materials
- Big flutes, easy chip removal
- Synchronized chip breakers
- Continued cut, good chip removal
- Polished finish

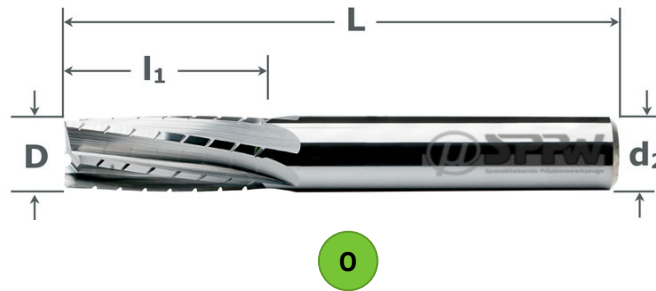

VHM	poliert
W 10°	z:6
DIN 6535HA	GFK CFK

ØD h10	Ød2 h6	L	l1	z	Art. No.	Stk/pce Euro	ØD h10	Ød2 h6	L	l1	z	Art. No.	Stk/pce Euro
2	6	57	7	6	7510660206	36,10	6	6	75	35	6	7510660601	51,10
3	6	57	12	6	7510660306	36,10	8	8	63	20	6	7510660800	53,10
4	6	57	20	6	7510660406	36,10	8	8	100	40	6	7510660801	70,70
5	6	57	16	6	7510660506	32,10	10	10	72	25	6	7510661000	73,20
6	6	57	18	6	7510660600	35,10	12	12	83	30	6	7510661200	102,30

751 066 HC

HSC-Schaftfräser VHM+Dia.HC GFK / CFK 6 Schneiden Carbide HSC End Mills+Dia.HC GFRP / CFRP 6 Flutes



- Faser-Verbundwerkstoffe
- Große Spannuten, gute Spanabfuhr
- Synchrone Spanbrecher
- Fortlaufender Schnitt
- Gerade Nuten, keine Zugkräfte
- Oberfläche Dia.HC beschichtet
- Fiber reinforced compound materials
- Big flutes, easy chip removal
- Synchronized chip breakers
- Continued cut, good chip removal
- With Dia.HC coating

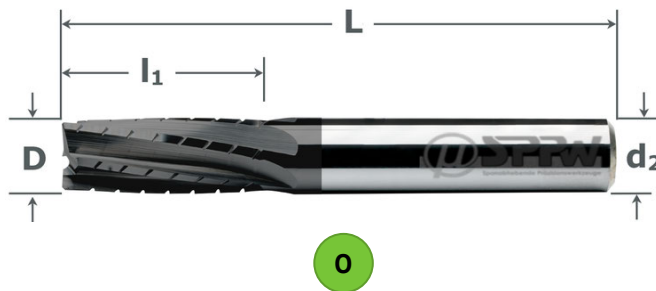

VHM	Dia HC
W 10°	z:6
DIN 6535HA	GFK CFK

ØD h10	Ød2 h6	L	l1	z	Art. No.	Stk/pce Euro	ØD h10	Ød2 h6	L	l1	z	Art. No.	Stk/pce Euro
2	6	57	7	6	7510660206HC	43,60	6	6	75	35	6	7510660601HC	58,60
3	6	57	12	6	7510660306HC	43,60	8	8	63	20	6	7510660800HC	61,50
4	6	57	20	6	7510660406HC	43,60	8	8	100	40	6	7510660801HC	79,00
5	6	57	16	6	7510660506HC	39,60	10	10	72	25	6	7510661000HC	83,20
6	6	57	18	6	7510660600HC	42,60	12	12	83	30	6	7510661200HC	115,30

— INFO —**Synchrone Spanbrecher**

Durch eine Reihe synchronisierter Spanbrecher, wird das Material kontinuierlich geschnitten, gleichzeitig die Fasern gebrochen und abtransportiert. Durch die hohe Anzahl an Schneiden wird eine deutlich bessere Schnittleistung und somit ein größeres Spanvolumen erreicht.

Synchronized Chip Breakers

A sequence of synchronized chipbreakers continuously cuts the material and simultaneously breaks and transports the fibers away. Due to the high number of cutting edges, a significantly better cutting performance and thus a larger chip volume is achieved.

751 080 HC

HSC-Nutfräser VHM+Dia.HC - Nutfräserspitze Carbide HSC End Mills+Dia.HC - Slot Drill Point



- FVK mit hohem Faseranteil
- Pyramidenverzahnung
- Ziehender Schnitt
- Nutfräser: Bohren, Nuten, Besäumen
- Extrem scharfe Schneidkanten
- Oberfläche Dia.HC beschichtet
- FRP with high fiber content
- Pyramid cross cut profile, up cut
- Slot drill drilling, slotting, trimming
- Extremely sharp cutting edges
- With Dia.HC coating

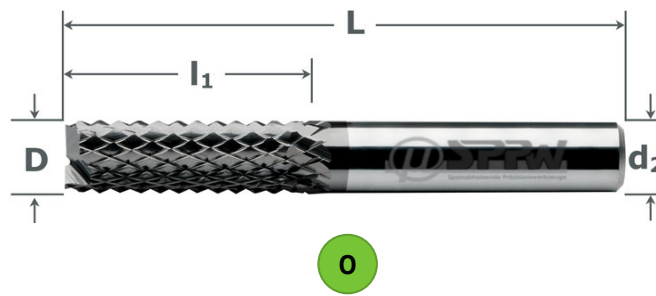

VHM	Dia HC
WX 30°	Multi
DIN 6535HA	GFK CFK

751080-F - fein | fine profile

ØD h10	Ød2 h6	L	l1	Art. No.	Stk/pce Euro	ØD h10	Ød2 h6	L	l1	Art. No.	Stk/pce Euro	ØD h10	Ød2 h6	L	l1	Art. No.	Stk/pce Euro
2	2	40	7	751080020FHC	20,90	5	5	50	16	751080050FHC	30,50	10	10	72	30	751080100FHC	61,40
2	6	50	7	751080026FHC	34,60	5	6	75	25	751080056FHC	48,60	12	12	83	32	751080120FHC	86,20
3	3	40	10	751080030FHC	20,90	6	6	50	18	751080060FHC	32,90	14	14	83	32	751080140FHC	145,20
3	6	50	12	751080036FHC	34,60	6	6	75	35	751080066FHC	50,70	16	16	92	36	751080160FHC	195,00
4	4	40	15	751080040FHC	23,90	8	8	63	25	751080080FHC	43,90	18	18	92	40	751080180FHC	228,90
4	6	50	20	751080046FHC	33,90	8	8	100	40	751080081FHC	67,70	20	20	104	45	751080200FHC	276,10

751080-M - mittel | medium profile

ØD h10	Ød2 h6	L	l1	Art. No.	Stk/pce Euro	ØD h10	Ød2 h6	L	l1	Art. No.	Stk/pce Euro	ØD h10	Ød2 h6	L	l1	Art. No.	Stk/pce Euro
2	2	40	7	751080020MHC	20,90	5	5	50	16	751080050MHC	30,50	10	10	72	30	751080100MHC	61,40
2	6	50	7	751080026MHC	34,60	5	6	75	25	751080056MHC	48,60	12	12	83	32	751080120MHC	86,20
3	3	40	10	751080030MHC	20,90	6	6	50	18	751080060MHC	32,90	14	14	83	32	751080140MHC	145,20
3	6	50	12	751080036MHC	34,60	6	6	75	35	751080066MHC	50,70	16	16	92	36	751080160MHC	195,00
4	4	40	15	751080040MHC	23,90	8	8	63	25	751080080MHC	46,30	18	18	92	40	751080180MHC	228,90
4	6	50	20	751080046MHC	32,90	8	8	100	40	751080081MHC	67,70	20	20	104	45	751080200MHC	276,10

751080-G - grob | coarse profile

ØD h10	Ød2 h6	L	l1	Art. No.	Stk/pce Euro	ØD h10	Ød2 h6	L	l1	Art. No.	Stk/pce Euro	ØD h10	Ød2 h6	L	l1	Art. No.	Stk/pce Euro
2	2	40	7	751080020GHC	20,90	5	5	50	16	751080050GHC	30,50	10	10	72	30	751080100GHC	61,40
2	6	50	7	751080026GHC	34,60	5	6	75	25	751080056GHC	48,60	12	12	83	32	751080120GHC	86,20
3	3	40	10	751080030GHC	20,90	6	6	50	18	751080060GHC	32,90	14	14	83	32	751080140GHC	145,20
3	6	50	12	751080036GHC	34,60	6	6	75	35	751080066GHC	50,70	16	16	92	36	751080160GHC	195,00
4	4	40	15	751080040GHC	23,90	8	8	63	25	751080080GHC	46,30	18	18	92	40	751080180GHC	228,90
4	6	50	20	751080046GHC	33,90	8	8	100	40	751080081GHC	67,70	20	20	104	45	751080200GHC	276,10

751 080

HSC-Nutfräser VHM - Nutfräserspitze Carbide HSC End Mills - Slot Drill Point



- FVK mit hohem Faseranteil
- Pyramidenverzahnung
- Ziehender Schnitt
- Nutfräser: Bohren, Nuten, Besäumen
- Extrem scharfe Schneidkanten
- Oberfläche poliert
- FRP with high fiber content
- Pyramid cross cut profile, up cut
- Slot drill: drilling, slotting, trimming
- Extremely sharp cutting edges
- Polished finish

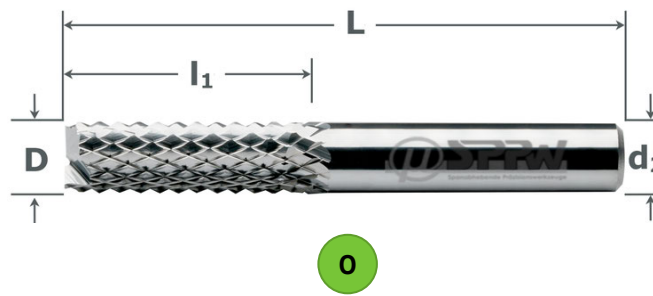

VHM	poliert
WX 30°	Multi
DIN 6535HA	GFK CFK

751080-F - fein | fine profile

ØD h10	Ød2 h6	L	l1	Art. No.	Stk/pce Euro	ØD h10	Ød2 h6	L	l1	Art. No.	Stk/pce Euro	ØD h10	Ød2 h6	L	l1	Art. No.	Stk/pce Euro
2	2	40	7	751080020F	14,30	5	5	50	16	751080050F	22,90	10	10	72	30	751080100F	52,00
2	6	50	7	751080026F	27,00	5	6	75	25	751080056F	41,10	12	12	83	32	751080120F	73,00
3	3	40	10	751080030F	14,30	6	6	50	18	751080060F	25,30	14	14	83	32	751080140F	127,70
3	6	50	12	751080036F	27,00	6	6	75	35	751080066F	43,20	16	16	92	36	751080160F	174,60
4	4	40	15	751080040F	17,40	8	8	63	25	751080080F	37,90	18	18	92	40	751080180F	206,70
4	6	50	20	751080046F	26,30	8	8	100	40	751080081F	59,30	20	20	104	45	751080200F	248,20

751080-M - mittel | medium profile

ØD h10	Ød2 h6	L	l1	Art. No.	Stk/pce Euro	ØD h10	Ød2 h6	L	l1	Art. No.	Stk/pce Euro	ØD h10	Ød2 h6	L	l1	Art. No.	Stk/pce Euro
2	2	40	7	751080020M	14,30	5	5	50	16	751080050M	22,90	10	10	72	30	751080100M	52,00
2	6	50	7	751080026M	27,00	5	6	75	25	751080056M	41,10	12	12	83	32	751080120M	73,00
3	3	40	10	751080030M	14,30	6	6	50	18	751080060M	25,30	14	14	83	32	751080140M	127,70
3	6	50	12	751080036M	27,00	6	6	75	35	751080066M	43,20	16	16	92	36	751080160M	174,60
4	4	40	15	751080040M	17,40	8	8	63	25	751080080M	37,90	18	18	92	40	751080180M	206,70
4	6	50	20	751080046M	26,30	8	8	100	40	751080081M	59,30	20	20	104	45	751080200M	248,20

751080-G - grob | coarse profile

ØD h10	Ød2 h6	L	l1	Art. No.	Stk/pce Euro	ØD h10	Ød2 h6	L	l1	Art. No.	Stk/pce Euro	ØD h10	Ød2 h6	L	l1	Art. No.	Stk/pce Euro
2	2	40	7	751080020G	14,30	5	5	50	16	751080050G	22,90	10	10	72	30	751080100G	52,00
2	6	50	7	751080026G	27,00	5	6	75	25	751080056G	41,10	12	12	83	32	751080120G	73,00
3	3	40	10	751080030G	14,30	6	6	50	18	751080060G	25,30	14	14	83	32	751080140G	127,70
3	6	50	12	751080036G	27,00	6	6	75	35	751080066G	43,20	16	16	92	36	751080160G	174,60
4	4	40	15	751080040G	17,40	8	8	63	25	751080080G	37,90	18	18	92	40	751080180G	206,70
4	6	50	20	751080046G	26,30	8	8	100	40	751080081G	59,30	20	20	104	45	751080200G	248,20

751 070 HC

HSC-Schaftfräser VHM+Dia.HC - Vielzahn-Stirnverzahnung Carbide HSC End Mills+Dia.HC - Multiflute Point



- FVK mit hohem Faseranteil
- Pyramidenverzahnung
- Ziehender Schnitt
- Vielzahn-Fräserstirn zum Stirnfräsen
- Extrem scharfe Schneidkanten
- Oberfläche Dia.HC beschichtet
- Fine: FRP with high fiber content
- Pyramid cross cut profile, up cut
- Multiflute point for front milling
- Extremely sharp cutting edges
- With Dia.HC coating

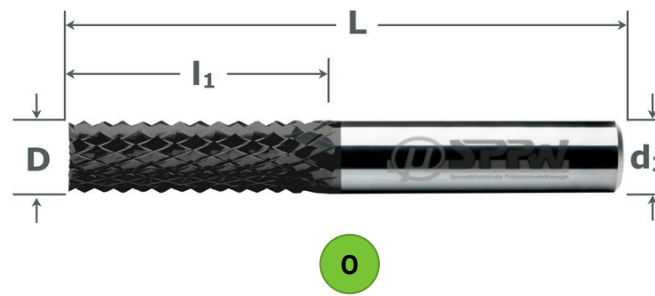

VHM	Dia HC
WX 30°	Multi
DIN 6535HA	GFK CFK

751070-F - fein | fine profile

ØD h10	Ød2 h6	L	l1	Art. No.	Stk/pce Euro	ØD h10	Ød2 h6	L	l1	Art. No.	Stk/pce Euro	ØD h10	Ød2 h6	L	l1	Art. No.	Stk/pce Euro
2	2	40	7	751070020FHC	20,10	5	5	50	16	751070050FHC	29,00	10	10	72	30	751070100FHC	59,30
2	6	50	7	751070026FHC	33,80	5	6	75	25	751070056FHC	47,20	12	12	83	32	751070120FHC	83,50
3	3	40	10	751070030FHC	20,10	6	6	50	18	751070060FHC	31,40	14	14	83	32	751070140FHC	142,90
3	6	50	12	751070036FHC	33,80	6	6	75	35	751070066FHC	49,20	16	16	92	36	751070160FHC	191,90
4	4	40	15	751070040FHC	22,90	8	8	63	25	751070080FHC	44,30	18	18	92	40	751070180FHC	225,20
4	6	50	20	751070046FHC	32,90	8	8	100	40	751070081FHC	65,70	20	20	104	45	751070200FHC	271,50

751070-M - mittel | medium profile

ØD h10	Ød2 h6	L	l1	Art. No.	Stk/pce Euro	ØD h10	Ød2 h6	L	l1	Art. No.	Stk/pce Euro	ØD h10	Ød2 h6	L	l1	Art. No.	Stk/pce Euro
2	2	40	7	751070020MHC	20,10	5	5	50	16	751070050MHC	29,00	10	10	72	30	751070100MHC	59,30
2	6	50	7	751070026MHC	33,80	5	6	75	25	751070056MHC	47,20	12	12	83	32	751070120MHC	83,50
3	3	40	10	751070030MHC	20,10	6	6	50	18	751070060MHC	31,40	14	14	83	32	751070140MHC	142,90
3	6	50	12	751070036MHC	33,80	6	6	75	35	751070066MHC	49,20	16	16	92	36	751070160MHC	191,90
4	4	40	15	751070040MHC	22,90	8	8	63	25	751070080MHC	44,30	18	18	92	40	751070180MHC	225,20
4	6	50	20	751070046MHC	32,90	8	8	100	40	751070081MHC	65,70	20	20	104	45	751070200MHC	271,50

751070-G - grob | coarse profile

ØD h10	Ød2 h6	L	l1	Art. No.	Stk/pce Euro	ØD h10	Ød2 h6	L	l1	Art. No.	Stk/pce Euro	ØD h10	Ød2 h6	L	l1	Art. No.	Stk/pce Euro
2	2	40	7	751070020GHC	20,10	5	5	50	16	751070050GHC	29,00	10	10	72	30	751070100GHC	59,30
2	6	50	7	751070026GHC	33,80	5	6	75	25	751070056GHC	47,20	12	12	83	32	751070120GHC	83,50
3	3	40	10	751070030GHC	20,10	6	6	50	18	751070060GHC	31,40	14	14	83	32	751070140GHC	142,90
3	6	50	12	751070036GHC	33,80	6	6	75	35	751070066GHC	49,20	16	16	92	36	751070160GHC	191,90
4	4	40	15	751070040GHC	22,90	8	8	63	25	751070080GHC	44,30	18	18	92	40	751070180GHC	225,20
4	6	50	20	751070046GHC	32,90	8	8	100	40	751070081GHC	65,70	20	20	104	45	751070200GHC	271,50

751 070**HSC-Schaftfräser VHM - Vielzahn-Stirnverzahnung
Carbide HSC End Mills - Multiflute Point**

- FVK mit hohem Faseranteil
- Pyramidenverzahnung
- Ziehender Schnitt
- Nutfräser: Bohren, Nuten, Besäumen
- Extrem scharfe Schneidkanten
- Oberfläche poliert
- Fine: FRP with high fiber content
- Pyramid cross cut profile, up cut
- Multiflute point for front milling
- Extremely sharp cutting edges
- Polished finish

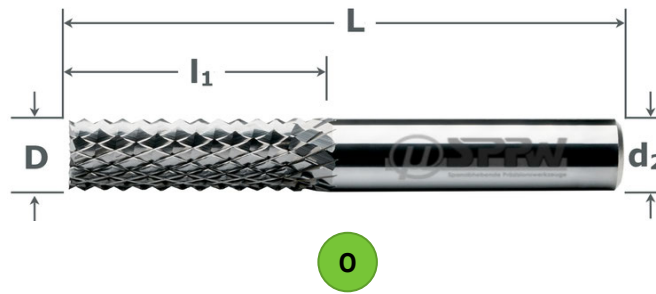

VHM	poliert
WX 30°	Multi
DIN 6535HA	GFK CFK

751070-F - fein | fine profile

ØD h10	Ød2 h6	L	l1	Art. No.	Stk/pce Euro	ØD h10	Ød2 h6	L	l1	Art. No.	Stk/pce Euro	ØD h10	Ød2 h6	L	l1	Art. No.	Stk/pce Euro
2	2	40	7	751070020F	13,50	5	5	50	16	751070050F	21,40	10	10	72	30	751070100F	49,90
2	6	50	7	751070026F	26,30	5	6	75	25	751070056F	39,60	12	12	83	32	751070120F	70,40
3	3	40	10	751070030F	13,50	6	6	50	18	751070060F	23,80	14	14	83	32	751070140F	125,30
3	6	50	12	751070036F	26,30	6	6	75	35	751070066F	41,70	16	16	92	36	751070160F	171,50
4	4	40	15	751070040F	16,40	8	8	63	25	751070080F	35,80	18	18	92	40	751070180F	202,90
4	6	50	20	751070046F	25,30	8	8	100	40	751070081F	57,30	20	20	104	45	751070200F	243,60

751070-M - mittel | medium profile

ØD h10	Ød2 h6	L	l1	Art. No.	Stk/pce Euro	ØD h10	Ød2 h6	L	l1	Art. No.	Stk/pce Euro	ØD h10	Ød2 h6	L	l1	Art. No.	Stk/pce Euro
2	2	40	7	751070020M	13,50	5	5	50	16	751070050M	21,40	10	10	72	30	751070100M	49,90
2	6	50	7	751070026M	26,30	5	6	75	25	751070056M	39,60	12	12	83	32	751070120M	70,40
3	3	40	10	751070030M	13,50	6	6	50	18	751070060M	23,80	14	14	83	32	751070140M	125,30
3	6	50	12	751070036M	26,30	6	6	75	35	751070066M	41,70	16	16	92	36	751070160M	171,50
4	4	40	15	751070040M	16,40	8	8	63	25	751070080M	35,80	18	18	92	40	751070180M	202,90
4	6	50	20	751070046M	25,30	8	8	100	40	751070081M	57,30	20	20	104	45	751070200M	243,60

751070-G - grob | coarse profile

ØD h10	Ød2 h6	L	l1	Art. No.	Stk/pce Euro	ØD h10	Ød2 h6	L	l1	Art. No.	Stk/pce Euro	ØD h10	Ød2 h6	L	l1	Art. No.	Stk/pce Euro
2	2	40	7	751070020G	13,50	5	5	50	16	751070050G	21,40	10	10	72	30	751070100G	49,90
2	6	50	7	751070026G	26,30	5	6	75	25	751070056G	39,60	12	12	83	32	751070120G	70,40
3	3	40	10	751070030G	13,50	6	6	50	18	751070060G	23,80	14	14	83	32	751070140G	125,30
3	6	50	12	751070036G	26,30	6	6	75	35	751070066G	41,70	16	16	92	36	751070160G	171,50
4	4	40	15	751070040G	16,40	8	8	63	25	751070080G	35,80	18	18	92	40	751070180G	202,90
4	6	50	20	751070046G	25,30	8	8	100	40	751070081G	57,30	20	20	104	45	751070200G	243,60

751 090 HC

HSC-Bohrfräser VHM+Dia.HC - Bohrerspitze Carbide HSC End Mills+Dia.HC - Drill Point



- FVK mit hohem Faseranteil
- Pyramidenverzahnung
- Ziehender Schnitt
- Bohrerspitze 135°: Bohren, Besäumen
- Extrem scharfe Schneidkanten
- Oberfläche Dia.HC beschichtet
- FRP with high fiber content
- Pyramid cross cut profile, up cut
- 135° drill point: drilling, trimming
- Extremely sharp cutting edges
- With Dia.HC coating

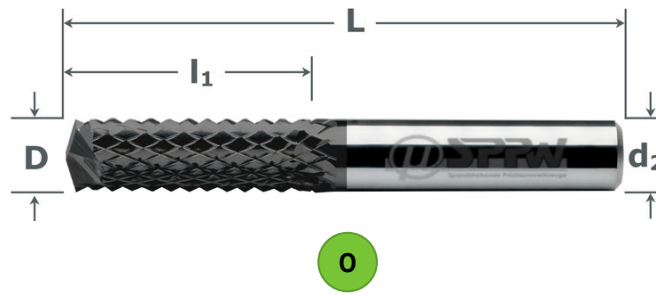

VHM	Dia HC
WX 30°	Multi
DIN 6535HA	GFK CFK

751090-F - fein | fine profile

ØD h10	Ød2 h6	L	l1	Art. No.	Stk/pce Euro	ØD h10	Ød2 h6	L	l1	Art. No.	Stk/pce Euro	ØD h10	Ød2 h6	L	l1	Art. No.	Stk/pce Euro
2	2	40	7	751090020FHC	22,20	5	5	50	16	751090050FHC	31,80	10	10	72	30	751090100FHC	63,30
2	6	50	7	751090026FHC	35,90	5	6	75	25	751090056FHC	50,00	12	12	83	32	751090120FHC	89,10
3	3	40	10	751090030FHC	22,20	6	6	50	18	751090060FHC	34,00	14	14	83	32	751090140FHC	149,80
3	6	50	12	751090036FHC	35,90	6	6	75	35	751090066FHC	51,70	16	16	92	36	751090160FHC	201,40
4	4	40	15	751090040FHC	25,00	8	8	63	25	751090080FHC	48,00	18	18	92	40	751090180FHC	235,80
4	6	50	20	751090046FHC	35,00	8	8	100	40	751090081FHC	69,30	20	20	104	45	751090200FHC	285,10

751090-M - mittel | medium profile

ØD h10	Ød2 h6	L	l1	Art. No.	Stk/pce Euro	ØD h10	Ød2 h6	L	l1	Art. No.	Stk/pce Euro	ØD h10	Ød2 h6	L	l1	Art. No.	Stk/pce Euro
2	2	40	7	751090020MHC	22,20	5	5	50	16	751090050MHC	31,80	10	10	72	30	751090100MHC	63,30
2	6	50	7	751090026MHC	35,90	5	6	75	25	751090056MHC	50,00	12	12	83	32	751090120MHC	89,10
3	3	40	10	751090030MHC	22,20	6	6	50	18	751090060MHC	34,00	14	14	83	32	751090140MHC	149,80
3	6	50	12	751090036MHC	35,90	6	6	75	35	751090066MHC	51,70	16	16	92	36	751090160MHC	201,40
4	4	40	15	751090040MHC	25,00	8	8	63	25	751090080MHC	48,00	18	18	92	40	751090180MHC	235,80
4	6	50	20	751090046MHC	35,00	8	8	100	40	751090081MHC	69,30	20	20	104	45	751090200MHC	285,10

751090-G - grob | coarse profile

ØD h10	Ød2 h6	L	l1	Art. No.	Stk/pce Euro	ØD h10	Ød2 h6	L	l1	Art. No.	Stk/pce Euro	ØD h10	Ød2 h6	L	l1	Art. No.	Stk/pce Euro
2	2	40	7	751090020GHC	22,20	5	5	50	16	751090050GHC	31,80	10	10	72	30	751090100GHC	63,30
2	6	50	7	751090026GHC	35,90	5	6	75	25	751090056GHC	50,00	12	12	83	32	751090120GHC	89,10
3	3	40	10	751090030GHC	22,20	6	6	50	18	751090060GHC	34,00	14	14	83	32	751090140GHC	149,80
3	6	50	12	751090036GHC	35,90	6	6	75	35	751090066GHC	51,70	16	16	92	36	751090160GHC	201,40
4	4	40	15	751090040GHC	25,00	8	8	63	25	751090080GHC	48,00	18	18	92	40	751090180GHC	235,80
4	6	50	20	751090046GHC	35,00	8	8	100	40	751090081GHC	69,30	20	20	104	45	751090200GHC	285,10

751 090

HSC-Bohrfräser VHM - Bohrerspitze Carbide HSC End Mills - Drill Point



- FVK mit hohem Faseranteil
- Pyramidenverzahnung
- Ziehender Schnitt
- Bohrerspitze 135°: Bohren, Besäumen
- Extrem scharfe Schneidkanten
- Oberfläche poliert
- Pyramid cross cut profile, up cut
- 135° drill point: drilling and trimming
- Extremely sharp cutting edges
- Fine: FRP with high fiber content
- Polished finish

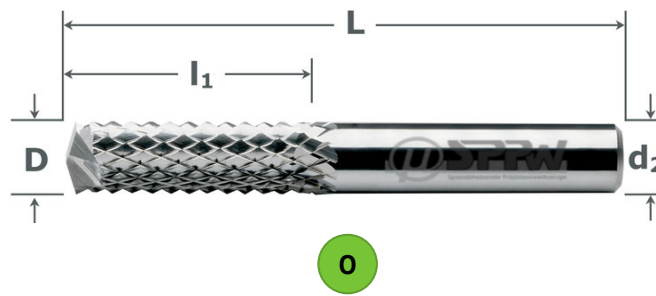

VHM	poliert
WX 30°	Multi
DIN 6535HA	GFK CFK

751090-F - fein | fine profile

ØD h10	Ød2 h6	L	l1	Art. No.	Stk/pce Euro	ØD h10	Ød2 h6	L	l1	Art. No.	Stk/pce Euro	ØD h10	Ød2 h6	L	l1	Art. No.	Stk/pce Euro
2	2	40	7	751090020F	15,60	5	5	50	16	751090050F	24,20	10	10	72	30	751090100F	53,90
2	6	50	7	751090026F	28,30	5	6	75	25	751090056F	42,40	12	12	83	32	751090120F	76,00
3	3	40	10	751090030F	15,60	6	6	50	18	751090060F	26,40	14	14	83	32	751090140F	132,30
3	6	50	12	751090036F	28,30	6	6	75	35	751090066F	44,20	16	16	92	36	751090160F	181,00
4	4	40	15	751090040F	18,40	8	8	63	25	751090080F	39,50	18	18	92	40	751090180F	213,50
4	6	50	20	751090046F	27,40	8	8	100	40	751090081F	61,00	20	20	104	45	751090200F	257,20

751090-M - mittel | medium profile

ØD h10	Ød2 h6	L	l1	Art. No.	Stk/pce Euro	ØD h10	Ød2 h6	L	l1	Art. No.	Stk/pce Euro	ØD h10	Ød2 h6	L	l1	Art. No.	Stk/pce Euro
2	2	40	7	751090020M	15,60	5	5	50	16	751090050M	24,20	10	10	72	30	751090100M	53,90
2	6	50	7	751090026M	28,30	5	6	75	25	751090056M	42,40	12	12	83	32	751090120M	76,00
3	3	40	10	751090030M	15,60	6	6	50	18	751090060M	26,40	14	14	83	32	751090140M	132,30
3	6	50	12	751090036M	28,30	6	6	75	35	751090066M	44,20	16	16	92	36	751090160M	181,00
4	4	40	15	751090040M	18,40	8	8	63	25	751090080M	39,50	18	18	92	40	751090180M	213,50
4	6	50	20	751090046M	27,40	8	8	100	40	751090081M	61,00	20	20	104	45	751090200M	257,20

751090-G - grob | coarse profile

ØD h10	Ød2 h6	L	l1	Art. No.	Stk/pce Euro	ØD h10	Ød2 h6	L	l1	Art. No.	Stk/pce Euro	ØD h10	Ød2 h6	L	l1	Art. No.	Stk/pce Euro
2	2	40	7	751090020G	15,60	5	5	50	16	751090050G	24,20	10	10	72	30	751090100G	53,90
2	6	50	7	751090026G	28,30	5	6	75	25	751090056G	42,40	12	12	83	32	751090120G	76,00
3	3	40	10	751090030G	15,60	6	6	50	18	751090060G	26,40	14	14	83	32	751090140G	132,30
3	6	50	12	751090036G	28,30	6	6	75	35	751090066G	44,20	16	16	92	36	751090160G	181,00
4	4	40	15	751090040G	18,40	8	8	63	25	751090080G	39,50	18	18	92	40	751090180G	213,50
4	6	50	20	751090046G	27,40	8	8	100	40	751090081G	61,00	20	20	104	45	751090200G	257,20

751 085 HC

HSC-Schaftfräser VHM+Dia.HC - Stirnradius Carbide HSC End Mills+Dia.HC - Stirnradius



- FVK mit hohem Faseranteil
- Pyramidenverzahnung
- Ziehender Schnitt
- Stirnradius für Kopierbearbeitung
- Extrem scharfe Schneidkanten
- Oberfläche Dia.HC beschichtet
- FRP with high fiber content
- Pyramid cross cut profile, up cut
- Radius for copying operations
- Extremely sharp cutting edges
- With Dia.HC coating

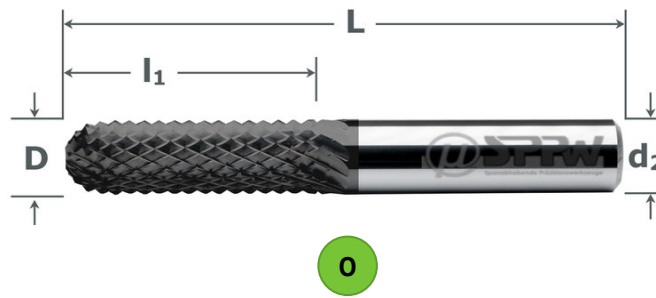

VHM	Dia HC
WX 30°	Multi
DIN 6535HA	GFK CFK

751085-F - fein | fine profile

ØD h10	Ød2 h6	L	l1	Art. No.	Stk/pce Euro	ØD h10	Ød2 h6	L	l1	Art. No.	Stk/pce Euro	ØD h10	Ød2 h6	L	l1	Art. No.	Stk/pce Euro
3	3	40	10	751085030FHC	21,50	5	6	75	25	751085056FHC	55,50	10	10	72	30	751085100FHC	60,90
3	6	50	12	751085036FHC	39,90	6	6	50	18	751085060FHC	32,70	12	12	83	32	751085120FHC	85,60
4	4	40	15	751085040FHC	24,90	6	6	75	35	751085066FHC	46,90	16	16	92	36	751085160FHC	194,00
4	6	50	20	751085046FHC	39,90	8	8	63	25	751085080FHC	46,30	20	20	104	45	751085200FHC	274,60
5	5	50	16	751085050FHC	31,70	8	8	100	40	751085081FHC	69,20						

751085-M - mittel | medium profile

ØD h10	Ød2 h6	L	l1	Art. No.	Stk/pce Euro	ØD h10	Ød2 h6	L	l1	Art. No.	Stk/pce Euro	ØD h10	Ød2 h6	L	l1	Art. No.	Stk/pce Euro
3	3	40	10	751085030MHC	21,50	5	6	75	25	751085056MHC	55,50	10	10	72	30	751085100MHC	60,90
3	6	50	12	751085036MHC	39,90	6	6	50	18	751085060MHC	33,00	12	12	83	32	751085120MHC	85,60
4	4	40	15	751085040MHC	24,90	6	6	75	35	751085066MHC	46,90	16	16	92	36	751085160MHC	194,00
4	6	50	20	751085046MHC	39,90	8	8	63	25	751085080MHC	46,30	20	20	104	45	751085200MHC	274,60
5	5	50	16	751085050MHC	31,70	8	8	100	40	751085081MHC	69,20						

— INFO —

Fräser für Schaumwerkstoffe

- Unterschiedliche Ausführungen und Längen
- Für Schäume mit verschiedenen Shore Härten

Auf Anfrage kurzfristig lieferbar

Milling Cutters for Foams

- Different versions and lengths
- For different Shore hardnesses

Available at short notice on request



751 085**HSC-Schaftfräser VHM - Stirnradius**
Carbide HSC End Mills - Radius

- FVK mit hohem Faseranteil
- Pyramidenverzahnung
- Ziehender Schnitt
- Stirnradius für Kopierbearbeitung
- Extrem scharfe Schneidkanten
- Oberfläche poliert

- Fine: FRP with high fiber content
- Pyramid cross cut profile, up cut
- Radius for copying operations
- Extremely sharp cutting edges
- Polished finish

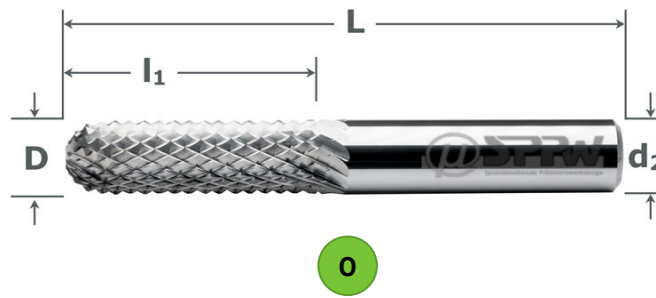

VHM	poliert
WX 30°	Multi
DIN 6535HA	GFK CFK

751085-F - fein | fine profile

ØD h10	Ød2 h6	L	l1	Art. No.	Stk/pce Euro	ØD h10	Ød2 h6	L	l1	Art. No.	Stk/pce Euro	ØD h10	Ød2 h6	L	l1	Art. No.	Stk/pce Euro
3	3	40	10	751085030F	14,40	5	6	75	25	751085056F	46,10	10	10	72	30	751085100F	51,20
3	6	50	12	751085036F	33,90	6	6	50	18	751085060F	25,00	12	12	83	32	751085120F	72,10
4	4	40	15	751085040F	18,10	6	6	75	35	751085066F	38,60	16	16	92	36	751085160F	172,90
4	6	50	20	751085046F	33,90	8	8	63	25	751085080F	37,60	20	20	104	45	751085200F	245,70
5	5	50	16	751085050F	23,80	8	8	100	40	751085081F	60,60	8	8	100	40	751085B082FHC-STKL	0,00

751085-M - mittel | medium profile

ØD h10	Ød2 h6	L	l1	Art. No.	Stk/pce Euro	ØD h10	Ød2 h6	L	l1	Art. No.	Stk/pce Euro	ØD h10	Ød2 h6	L	l1	Art. No.	Stk/pce Euro
3	3	40	10	751085030M	14,40	5	6	75	25	751085056M	46,10	10	10	72	30	751085100M	51,20
3	6	50	12	751085036M	33,90	6	6	50	18	751085060M	24,20	12	12	83	32	751085120M	72,10
4	4	40	15	751085040M	18,10	6	6	75	35	751085066M	38,60	16	16	92	36	751085160M	172,90
4	6	50	20	751085046M	33,90	8	8	63	25	751085080M	37,60	20	20	104	45	751085200M	245,70
5	5	50	16	751085050M	23,80	8	8	100	40	751085081M	60,60						

— INFO —**Fräser mit Pyramidenverzahnung zur Bearbeitung von Kompositen**

Pyramidverzahnte Fräser werden in einem speziellen Schleifverfahren hergestellt. Es kombiniert zwei wichtige Eigenschaften: polierte Spannuten und scharfe Schneidkanten.

- Geringer Reibungskoeffiziente
- Hohe Schnitthaltigkeit
- Bessere Spanabfuhr
- Lange Werkzeuglebensdauer

End Mills with Pyramid Cross Cut Profile for Composite Materials

Pyramid cross cut end mills are produced with special grinding method. It combines two important elements: polished flutes and sharp cutting edges.

- Low friction coefficient
- High cutting accuracy
- Better chip evacuation
- Longer tool life

792 644**HSC-Torusfräser VHM+Diamant Lang + Überlang**
Carbide Torical HSC End Mills+Diamond Long + Extra Long

- Grafit und Grünlinge
- Lange und überlange Ausführung
- Freistellung nach der Schneide
- Eckenradius für Kopierarbeiten
- Oberfläche Diamant beschichtet

- Graphite and greens
- Long and extra long series
- Back clearance after primary edge
- Corner radius for copying operations
- With diamond coating

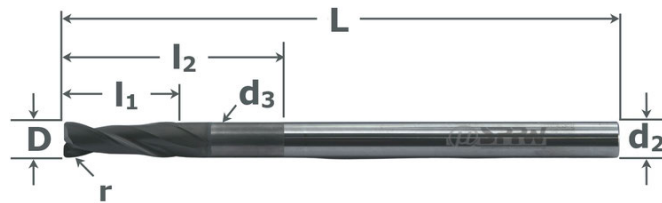

VHM	DIA Graph
z:2	DIN 6535HA
L lang	Grafit

ØD h10	Ød2 h6	L	l1	l2	z	r Radius	Ød3	Art. No.	Stk/pce Euro
2	3	50	6	12	2	0,5	1,9	7926440205	41,90
2	3	100	10	20	2	0,5	1,9	7926440210	45,30
3	3	60	8	16	2	0,5	2,9	7926440306	41,90
3	3	100	12	24	2	0,5	2,9	7926440310	45,30
4	4	60	10	20	2	0,5	3,8	7926440406	59,40
4	4	100	15	30	2	0,5	3,8	7926440410	62,30
5	5	60	12	24	2	0,5	4,8	7926440506	73,70
5	5	100	15	30	2	0,5	4,8	7926440510	79,40
6	6	75	20	40	2	0,5	5,8	7926440607	86,20
6	6	100	25	50	2	0,5	5,8	7926440610	93,00

ØD h10	Ød2 h6	L	l1	l2	z	r Radius	Ød3	Art. No.	Stk/pce Euro
6	6	150	30	60	2	0,5	5,8	7926440615	103,40
8	8	75	20	40	2	1	7,8	7926440807	120,40
8	8	100	25	50	2	1	7,8	7926440810	130,10
8	8	150	30	60	2	1	7,8	7926440815	145,70
10	10	100	25	50	2	1	9,8	7926441010	161,00
10	10	150	30	60	2	1	9,8	7926441015	178,30
12	12	100	25	50	2	1	11,8	7926441210	190,30
12	12	150	40	80	2	1	11,8	7926441215	224,80
16	16	100	25	50	2	1,5	15,8	7926441610	292,10
16	16	150	40	80	2	1,5	15,8	7926441615	329,40

792 645**HSC-Radiusfräser VHM+Diamant Lang + Überlang**
Carbide HSC Radius End Mills+Diamond Long + Extra Long

- Grafit und Grünlinge
- Lange und überlange Ausführung
- Freistellung nach der Schneide
- Stirnradius für Kopierarbeiten
- Oberfläche Diamant beschichtet

- Graphite and greens
- Long and extra long series
- Back clearance after primary edge
- Radius for copying operations
- With diamond coating

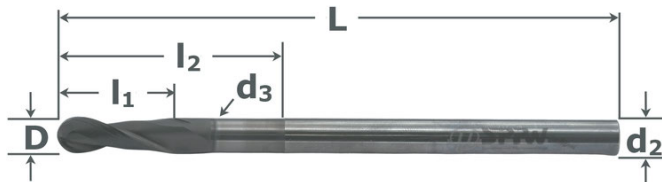

VHM	DIA Graph
z:2	DIN 6535HA
L lang	Grafit

ØD h10	Ød2 h6	L	l1	l2	z	Ød3	Art. No.	Stk/pce Euro
2	3	50	6	12	2	1,9	7926450205	41,90
2	3	100	10	20	2	1,9	7926450210	45,30
3	3	60	8	16	2	2,9	7926450306	43,00
3	3	100	12	24	2	2,9	7926450310	45,30
4	4	60	10	20	2	3,8	7926450406	59,40
4	4	100	15	30	2	3,8	7926450410	62,30
5	5	60	12	24	2	4,8	7926450506	73,70
5	5	100	15	30	2	4,8	7926450510	79,40
6	6	75	20	40	2	5,8	7926450607	86,20
6	6	100	25	50	2	5,8	7926450610	93,10

ØD h10	Ød2 h6	L	l1	l2	z	Ød3	Art. No.	Stk/pce Euro
6	6	150	30	60	2	5,8	7926450615	103,40
8	8	75	20	40	2	7,8	7926450807	120,40
8	8	100	25	50	2	7,8	7926450810	130,10
8	8	150	30	60	2	7,8	7926450815	145,70
10	10	100	25	50	2	9,8	7926451010	161,00
10	10	150	30	60	2	9,8	7926451015	178,30
12	12	100	25	50	2	11,8	7926451210	190,30
12	12	150	40	80	2	11,8	7926451215	224,80
16	16	100	25	50	2	15,8	7926451610	292,10
16	16	150	40	80	2	15,8	7926451615	329,40

551 100

Einzahnfräser HSS-E für Kopiermaschinen HSS-E HSC Single Flute End Mills



- Leichtlegierungen und Kunststoffe
 - Fenster, Türen, Ladenbau
 - Rechtsschneidend mit Rechtsspirale
 - Zentrumschnitt zum Tauchen
 - Verstärkter Schaft 8mm
 - Oberfläche blank
- Für Elu, Haffner, Rotox und andere

- Light alloys and plastics
 - Windows, door and shop fronts
 - Right hand helix, right hand cutting
 - Center cutting for plunging
 - Reinforced shank 8mm
 - Bright finish
- For Élu, Haffner, Rotox and others

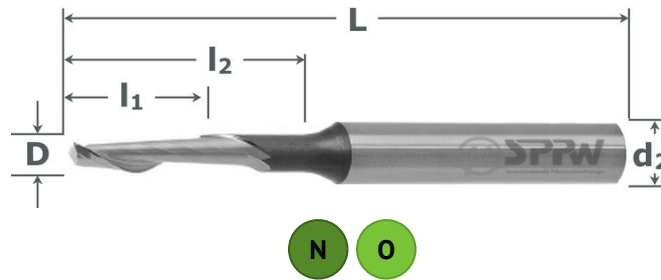

HSS E05	blank
Typ W	z:1
Shaft 8mm	

ØD k10	d2 h6	L	l1	l2	Art. No.	Stk/pce Euro	ØD k10	d2 h6	L	l1	l2	Art. No.	Stk/pce Euro
3	8	60	12		5511000300	13,10	8	8	80	14		5511000800	14,10
4	8	60	12		5511000400	13,10	8	8	80	14	54	5511000801	17,60
5	8	80	18	35	5511000500	17,60	8	8	120	14		5511000802	20,60
5	8	60	18		5511000501	14,10	10	8	80	14		5511001000	18,50
5	8	60	16	45	5511000502	19,70	12	8	80	14		5511001200	22,00
6	8	60	14		5511000600	14,10							

— INFO —



Spezielle Anwendungen

Für besondere Bearbeitungsaufgaben werden oft sehr spezielle Werkzeuge benötigt. Wir haben das Know-How und die Werkzeuge. Beispielsweise zum Kanten von Verbundplatten in der Werbetechnik oder Fräsbearbeitung von Baustoffen wie Gasbeton oder Granit in der Architektur.

Special Applications

Often very special tools are required for special machining tasks. We have the know-how and the tools. For example, for edging composite panels in advertising technology or milling building materials such as aerated concrete or granite in architecture.

552 480

Schaftfräser HSS-E08 - Leichtlegierungen HSS-E08 End Mills - Light Alloys



- Leichtlegierungen und NE-Metalle
- Weite Spanräume für gute Spanabfuhr
- Zentrumschnitt zum Tauchen
- Kurze Ausführung mit 40° Spirale
- Schaft DIN 1835 B mit Spannfläche
- Oberfläche blank

- Light alloys and non-ferrous metals
- Wide flutes for good chip evacuation
- Center cutting for plunging
- Short series with 40° helix
- Flatted shank DIN 1835 B
- Bright finish

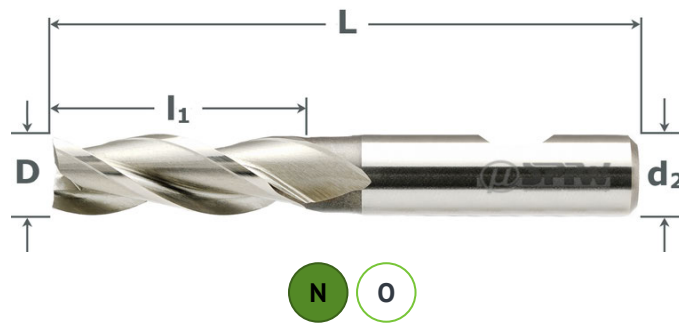

HSS E08	blank
DIN 844K	Typ W
z: 3	DIN 1835B

ØD h10	Ød2 h6	L	l1	z	Art. No.	Stk/pce Euro	ØD h10	Ød2 h6	L	l1	z	Art. No.	Stk/pce Euro
2	6	51	7	3	5524800200	12,40	9	10	69	19	3	5524800900	18,00
3	6	52	8	3	5524800300	11,30	10	10	72	22	3	5524801000	16,40
4	6	55	11	3	5524800400	11,30	12	12	83	26	3	5524801200	19,10
5	6	57	13	3	5524800500	11,30	14	12	83	26	3	5524801400	28,40
6	6	57	13	3	5524800600	12,20	16	16	92	32	3	5524801600	32,00
7	10	66	16	3	5524800700	15,80	18	16	92	32	3	5524801800	45,00
8	10	69	19	3	5524800800	14,40	20	20	104	38	3	5524802000	51,30

552 580

Schaftfräser HSS-E08 Lang - Leichtlegierungen HSS-E08 End Mills Long Series Light Alloys



- Leichtlegierungen und NE-Metalle
- Weite Spanräume für gute Spanabfuhr
- Zentrumschnitt zum Tauchen
- Lange Ausführung mit 40° Spirale
- Schaft DIN 1835 B mit Spannfläche
- Oberfläche blank

- Light alloys and non-ferrous metals
- Wide flutes for good chip evacuation
- Center cutting for plunging
- Long series with 40° helix
- Flatted shank DIN 1835 B
- Bright finish

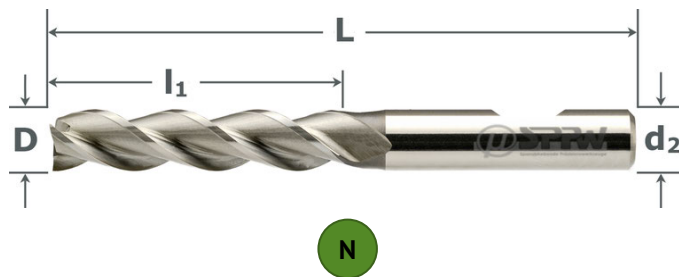

HSS E08	blank
DIN 844L	Typ W
z:3	DIN 1835B

ØD k10	Ød2 h6	L	l1	z	Art. No.	Stk/pce Euro	ØD k10	Ød2 h6	L	l1	z	Art. No.	Stk/pce Euro
6	6	68	24	3	5525800600	18,90	14	12	110	53	3	5525801400	43,40
8	10	82	88	3	5525800800	22,50	16	16	123	63	3	5525801600	49,50
10	10	95	45	3	5525801000	26,30	18	16	123	63	3	5525801800	70,20
12	12	110	53	3	5525801200	30,20	20	20	141	75	3	5525802000	80,10