

625 334

## Schneidplatten VHM standard für 4-in-1 Bohrer X.Cut 4-in-1 Counter Bore Inserts standard X.Cut



- Schneidplatten für 4-in-1 Bohrer
- DIN373, metrische Senkungen 180°
- Anbohren, Senken, Fasen, Zentrieren
- M C350 X5.Cut für Stahlwerkstoffe
- VE: 5 / ab Ø20 VE: 3

- Inserts for 4-in-1 counter bores
- DIN373, metric counter bores 180°
- Spot, bore, chamfer, center
- 45° chamfer on top of the bore
- M C350 X5.Cut coating for steels
- PU: 5 / from Ø20 PU: 3

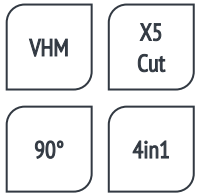
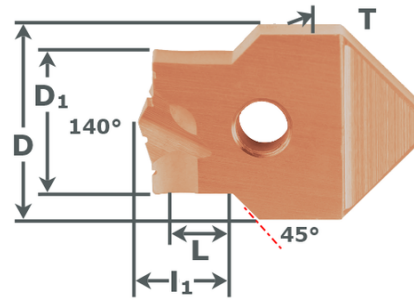
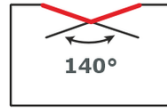
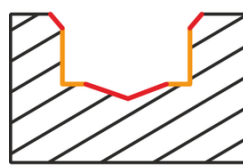

### 625334 - M12 X5.Cut

ØM	ØD	D1	L	T	Art. No.	Stk/pce Euro
12	20	17	8	3,5	6253342012	42,40