

625 333

Schneidplatten VHM standard für 4-in-1 Bohrer X.Cut Carbide 4-in-1 Counter Bore Inserts X.Cut



- Schneidplatten für 4-in-1 Bohrer
- DIN373, metrische Senkungen 180°
- Anbohren, Senken, Fasen, Zentrieren
- M B350 X.Cut für Stahl, Inox
- VE: 5 / ab Ø20 VE: 3

- Inserts for 4-in-1 counter bores
- DIN373, metric counter bores 180°
- Spot, bore, chamfer, center
- 45° chamfer on top of the bore
- M B350 X.Cut for steels, stainless
- PU: 5 / from Ø20 PU: 3

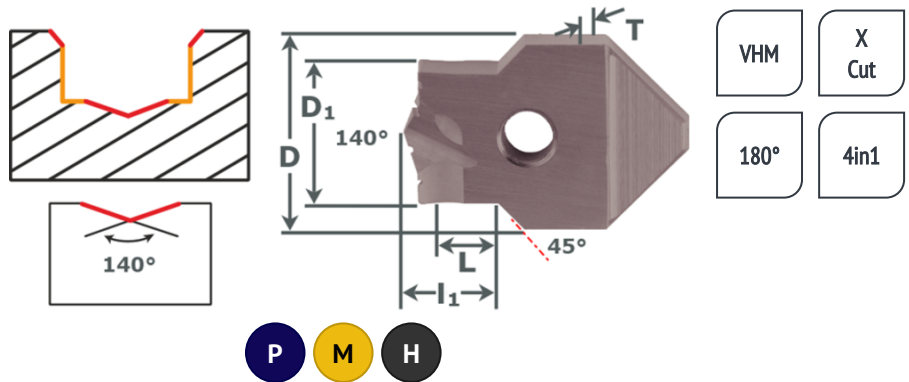

625333 - Standard

| ØM | ØD | D1 | L | l1 | T | Art. No. | Stk/pce Euro | ØM | ØD | D1 | L | l1 | T | Art. No. | Stk/pce Euro |
|-----|----|-----|-----|-----|-----|------------|-----------------|----|----|----|------|-----|-----|------------|-----------------|
| 3,5 | 8 | 6,5 | 3,1 | 3,7 | 2 | 6253330830 | 32,80 | 6 | 12 | 11 | 6,4 | 7,4 | 3 | 6253331260 | 39,30 |
| 4 | 10 | 8 | 4,2 | 5 | 2,5 | 6253331040 | 36,00 | 8 | 16 | 15 | 8,4 | 9,8 | 3 | 6253331680 | 42,90 |
| 5 | 12 | 10 | 5,3 | 6,2 | 3 | 6253331250 | 39,30 | 10 | 20 | 18 | 10,3 | 12 | 3,5 | 6253332010 | 46,60 |