

625 323

Schneidplatten VHM für 4-in-1 Bohrer X.Cut  
Carbide 4-in-1 Counter Bore Inserts X.Cut



- Schneidplatten für 4-in-1 Bohrer
- DIN373, metrische Senkungen 180°
- Anbohren, Senken, Fasen, Zentrieren
- M B350 X.Cut für Stahl und Inox
- VE: 5 / ab Ø20 VE: 3

- Inserts for 4-in-1 counter bores
- DIN373, metric counter bores 180°
- Spot, bore, chamfer, center
- 45° chamfer on top of the bore
- M B350 X.Cut for steels, stainless
- PU: 5 / from Ø20 PU: 3

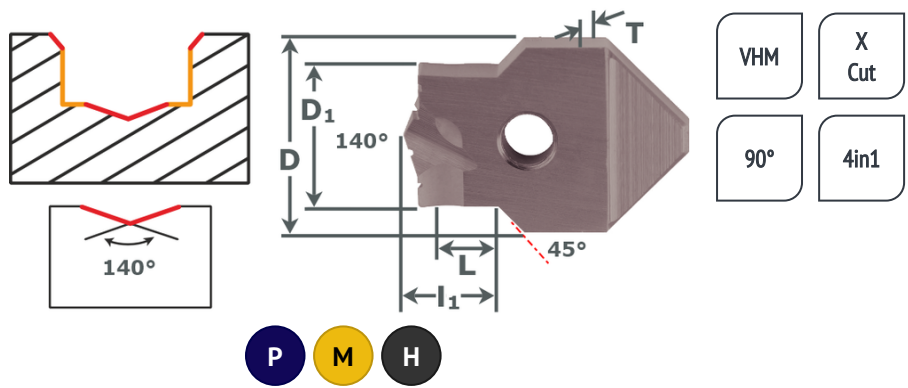

625323 - eng | narrow

ØM	ØD	D1	L	l1	T	Art. No.	Stk/pce Euro	ØM	ØD	D1	L	l1	T	Art. No.	Stk/pce Euro
3	8	5,8	3,1	3,7	2	6253230830	32,80	7	16	11,5	7,4	8,4	3	6253231670	42,90
3,5	8	6,3	3,6	4,3	2	6253230835	32,80	8	16	13,5	8,4	9,8	3	6253231680	42,90
4	10	7,4	4,2	5	2,5	6253231040	36,00	10	20	16,5	10,3	12	3,5	6253232010	46,60
5	12	9,3	5,3	6,2	3	6253231250	39,30	12	20	19	12,3	14,5	3,5	6253232012	46,60
6	12	10,4	6,4	7,4	3	6253231260	39,30								

— INFO —

— INFO —

Effiziente Bearbeitung mit dem 4-in-1 Formbohrer | Working Efficiently with the 4-in-1 counter bore

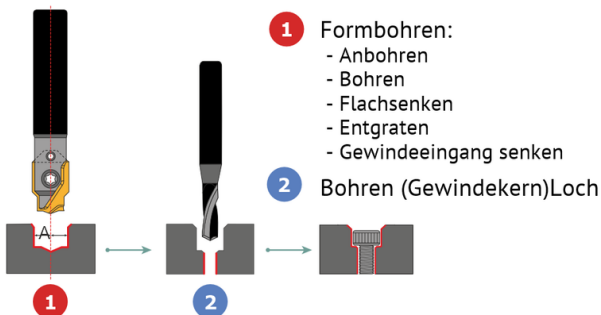
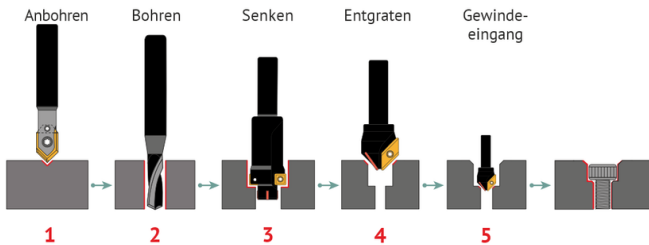

Mit dem 4-in-1 Formbohrer lassen sich 4 Arbeitsschritte einsparen - statt 5 Operationen (Anbohren, Bohren, Senken, Entgraten und Gewindeeingang senken) sind nur noch 2 notwendig (Formbohren und Bohren)

- Hohe Zentriergenauigkeit, minimierte Exzentrizität ±0,008 mm.
- Fertige Senkung innerhalb von 3 Sekunden
- Weniger Werkzeugwechsel

The 4-in-1 form drill allows you to skip 4 operations - instead of 5 operations (spotting, drilling, countersinking, deburring, tap hole entry chamfering), only 2 are necessary (form drilling and drilling)

- Extremely accurate positioning, minimized eccentricity ±0.008mm
- Create a counter bore within 3 seconds
- Fewer tool changes