

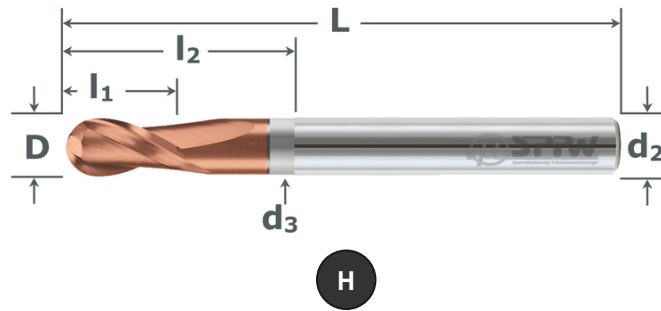

- HSC-Kopierbearbeitung
- Gehärtete Stähle bis 65 HRC
- Kurze Ausführung mit Stirnradius
- Glatter Schaft DIN 6535 HA
- Oberfläche X.Cut beschichtet
- HSC copy milling operations
- Hardened steels up to 65 HRC
- Short series, radius
- Straight shank DIN 6535 HA
- With X.Cut coating



VHM	X Cut
HSC-H 40°	z:2
DIN 6535HA	65 HRC

**752425 - kurz | short series**

ØD h10	Ød2 h6	L	l1	l2	z	R ±0,01	Ød3	Art. No.	Stk/pce Euro	ØD h10	Ød2 h6	L	l1	l2	z	R ±0,01	Ød3	Art. No.	Stk/pce Euro
2	6	57	3	7	2	1	1,9	7524250200	51,80	6	6	57	7	19	2	3	5,5	7524250600	43,80
3	6	57	4	10	2	1,5	2,8	7524250300	51,80	8	8	63	9	25	2	4	7,4	7524250800	59,80
4	6	57	5	13	2	2	3,7	7524250400	52,70	10	10	72	11	31	2	5	9,2	7524251000	82,40
5	6	57	6	16	2	2,5	4,6	7524250500	52,90	12	12	83	13	37	2	6	11	7524251200	108,90

