

678 460

Vor- und Rückwärtsentgrater VHM+X.Cut Bi-Face 60°
Carbide Forward / Backward Deburrer+X.Cut Bi-Face 60°

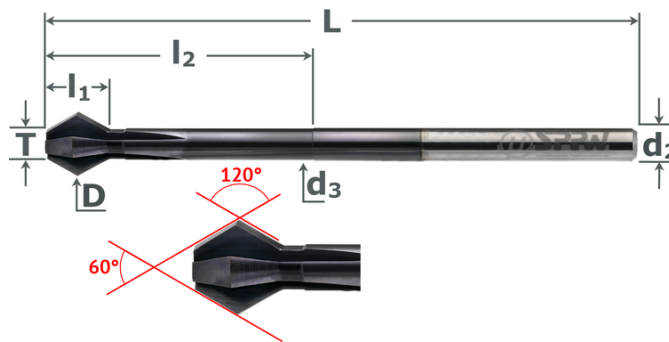

- Zum Rückwärts-, Entgraten, Fasen
- Lange Ausführung
- Beidseitig geschliffener Kopf
- Winkel 60°
- Oberfläche X.Cut beschichtet
- Front/back deburring and chamfering
- Long version
- For difficult access
- Chamfering angle 60°
- With X.Cut coating



VHM	X Cut
60° 120°	z: 3-4
DIN 6535HA	L lang



ØD	Ød2	Ød3	L	l1	l2	z	T	Art. No.	Stk/pce Euro	ØD	Ød2	Ød3	L	l1	l2	z	T	Art. No.	Stk/pce Euro
	h6	max.	-1	min.	max.						h6	max.	-1	min.	max.				
2	3	1,5	100	1,7	8	3	0,6	6784600200	60,50	8	6	4,9	100	5,4	34	4	4,9	6784600800	86,70
5	6	3,4	100	2,8	15	4	3,4	6784600500	66,10	12	6	5,9	100	10,6	34	4	5,9	6784601200	126,40

— INFO —



SONDER | SPECIALS

Wir liefern Sonderanfertigungen in Ihrer gewünschten Abmessung!
We supply special tools in your desired dimensions!

