

668 092

Multifunktionswerkzeuge VHM 120°
Carbide Multifunction Tools 120°

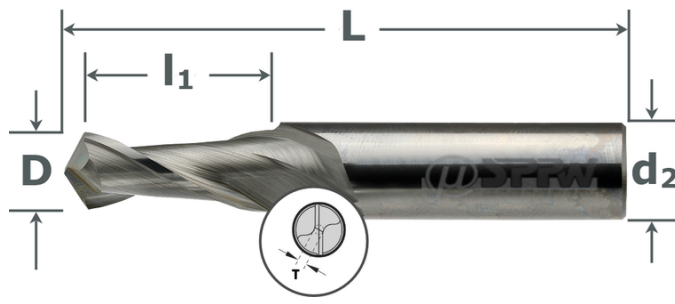

- Fräsen, Bohren, Senken, 1 Werkzeug
- Besonders geeignet auf CNC-BAZ
- Senkt Rüstzeit und Bevorratung
- Senkwinkel 120°
- Oberfläche blank
- Milling, drilling, chamfering, 1 tool
- Use on CNC or automatic machines
- Short set up-, work time, easy storage
- Chamfering angle 120°
- Bright finish



VHM	poliert
120°	z:2
DIN 6535HA	Multi V

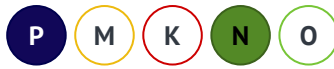

668092 - 120°

ØD h9	Ød2 h6	L	l1	z	T	a	Art. No.	Stk/pce Euro
1	3	39	2	2	0,1	120°	6680920100	23,10
1,5	3	39	3	2	0,15	120°	6680920150	23,10
2	3	39	4	2	0,2	120°	6680920200	23,10
2,5	3	39	5	2	0,25	120°	6680920250	23,10
3	4	50	6	2	0,3	120°	6680920300	27,80
4	5	50	8	2	0,4	120°	6680920400	29,20
5	6	50	10	2	0,5	120°	6680920500	30,70

ØD h9	Ød2 h6	L	l1	z	T	a	Art. No.	Stk/pce Euro
6	8	60	12	2	0,6	120°	6680920600	36,60
8	10	70	16	2	0,8	120°	6680920800	51,20
10	12	70	18	2	1	120°	6680921000	67,20
12	12	70	20	2	1,2	120°	6680921200	70,20
16	16	80	26	2	1,6	120°	6680921600	102,30
20	20	100	32	2	2	120°	6680922000	166,70

— INFO —

— INFO —

Multifunktional ...

