

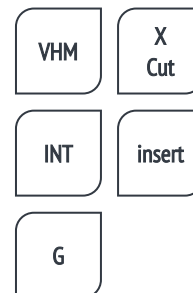

- Für Innengewinde
- Gesinterte Spanbrecher
- LH und Multiverzahnung auf Anfrage
- Oberfläche X.Cut (Typ BC mit A.Cut)
- Lieferzeit ca. 5 - 8 Arbeitstage

- For internal threads
- LH sintered chip breakers
- Multi tooth on request
- With X.Cut (type BC with A.Cut)
- Delivery time 5 - 8 working days

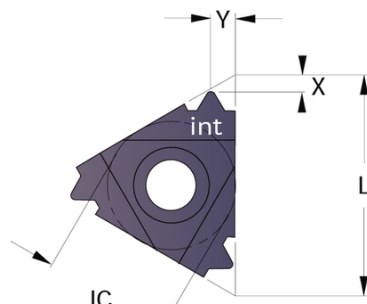

**G - Whitworth**

Stg.	L	IC	X	Y	Typ	Art. No.	Stk/pce Euro	Stg.	L	IC	X	Y	Typ	Art. No.	Stk/pce Euro
19	8	3/16	0,6	0,7	Int.	08IR19WBC	19,09	11	16	3/8	1,1	1,5	Int.	16IR11WFC	15,80
28	8	3/16	0,6	0,6	Int.	08IR28WBC	19,09	14	16	3/8	1	1,2	Int.	16IR14WFC	14,50
19	11	1/4	0,8	1	Int.	11IR19WFC	14,50								

